

ARIELTECH[®]

FAN FILTERS | EXHAUST FILTERS | AXIAL FANS | HEATERS
THERMOSTATS | HYGROSTAT | THERMOELECTRIC COOLING UNITS
ELECTRONIC THERMOSTAT | ELECTRONIC HUMIDISTAT

THERMAL
MANAGEMENT
SOLUTIONS

CATALOG



Ariel Technology Inc.

9-1111 Gorham St., Newmarket, Ontario, Canada L3Y 8X8

Tel: 1-905-895-5900 • Fax: 1-905-895-5960 • (USA/Canada) Toll Free 1-855-895-5900 • info@arieltech.ca

www.arieltech.ca

INDEX

Fan Filters
Exhaust Filters

04

Axial Fans

24

Mechanical Thermostats
Normally Open & Normally Closed

26

Humidity Control
Mechanical Hygrostat

28

Electronic Thermostat

30

Electronic Hygrostat

32

Heaters

34

Thermoelectric
Cooling Units

36

Accessories

38

Warranty

39



ABOUT ARIELTECH

Manufacturers of control panel and electrical enclosure Thermal Management solutions.

Arieltech is more than just dedicated to giving you the very best solutions that will keep your control panels warm, cool, or dry. We are innovators, we bring new and innovative industrial Thermal Management solutions to the market that are driven by the needs of our valued customers.

We serve customers all over the world.

Lead by a team of professional engineers, sales and marketing teams with a combined 80+ years of industrial experience, and a strong customer-focused approach.

Our facility is nestled just north of Toronto and is our state-of-the-art design, engineering, manufacturing, sales, and assembly hub. We manufacture a complete line of Thermal Management solutions that will exceed your expectations.

Mission Statement

Make the best quality thermal management products, innovate and exceed our customer's expectations



Fan Filters and Exhaust Filters

FTEC Series

FTEC

Certificates

- UL and cUL Listed, File Number E497874
- CSA and CSAus Listed, File Number 80030884
- CE Compliant

Application

FTEC series Fan Filters and Exhaust Filters are designed to supply forced convection filtered air for enclosures and electrical panels. By using the unique filtering and cooling features, FTEC will cool down the inside of enclosures to a desired temperature to protect the electrical and electronic parts against heat.

Features

- Type 12 and Type 3R NEMA Rating-NO HOOD REQUIRED
- IP 54 using G3 filter mat and IP 55 using G4 filter mat
- 115 VAC, 230 VAC, 460 VAC, 12, 24, and 48 VDC available
- Flow capacity from 15 CFM to 625 CFM (26 m³/hr to 1060 m³/hr)
- Polyurethane sealing gasket
- Ball bearing Fan
- Easily snaps into place without the use of screws
- Washable and reusable filter mat
- Robust flame-retardant plastic housing, UL 94-V0
- Operating/Storage Temperature: -4 °F to +158 °F / -20 °C to +70 °C
- Durability: 50,000 - 90,000 hrs
- UV Resistant

Colors

- RAL 7035 – Light Gray
- RAL 7032 – Dark Gray
- RAL 9011 – Black
- Custom Colors upon request



Selection Chart Fan Filters and Exhaust Filters

Model No.		Size	Voltage	NEMA Rating	Type Rating	Unimpeded Flow Capacity	In combination Flow Capacity	Certificates
		Inch-mm	VAC/VDC			CFM-m ³ /hr	CFM-m ³ /hr	
FTEC10(*)4X	Exhaust Filter	4-110X110	-	TYPE 12	IP 54	-	-	UL-CSA-CE
FTEC10(*)4X-115SB	Fan Filter		115 AC			15-26	11-19	UL-CSA-CE
FTEC10(*)4X-230SB			230 AC			15-26	11-19	UL-CSA-CE
FTEC10(*)4X-(**)SB			12/24/48 DC	38-65	26-45	UL-CSA-CE		
FTEC10(*)5(***)	Exhaust Filter		-	TYPE 12 or TYPE 3R	IP 55	-	-	UL-CSA-CE
FTEC10(*)5(***)-115SB	Fan Filter		115 AC			14-24	10-17	UL-CSA-CE
FTEC10(*)5(***)-230SB			230 AC			14-24	10-17	UL-CSA-CE
FTEC10(*)5(***)-(**)SB			12/24/48 DC	35-60	22-37	UL-CSA-CE		
FTEC16(*)4X	Exhaust Filter		6-116X116	-	TYPE 12	IP 54	-	-
FTEC16(*)4X-115SB	Fan Filter	115 AC		42-70			35-60	UL-CSA-CE
FTEC16(*)4X-230SB		230 AC		42-70			35-60	UL-CSA-CE
FTEC16(*)4X-(**)SB		12/24/48 DC		42-70	35-60	UL-CSA-CE		
FTEC16(*)5(***)	Exhaust Filter	-		TYPE 12 or TYPE 3R	IP 55	-	-	UL-CSA-CE
FTEC16(*)5(***)-115SB	Fan Filter	115 AC				35-60	30-50	UL-CSA-CE
FTEC16(*)5(***)-230SB		230 AC				35-60	30-50	UL-CSA-CE
FTEC16(*)5(***)-(**)SB		12/24/48 DC		35-60	30-50	UL-CSA-CE		
FTEC20(*)4X	Exhaust Filter	8-206X206		-	TYPE 12	IP 54	-	-
FTEC20(*)4X-115SB	Fan Filter		115 AC	95-160			70-120	UL-CSA-CE
FTEC20(*)4X-230SB			230 AC	95-160			70-120	UL-CSA-CE
FTEC20(*)4X-(**)SB			12/24/48 DC	90-152	70-120	UL-CSA-CE		
FTEC20(*)5(***)	Exhaust Filter		-	TYPE 12 or TYPE 3R	IP 55	-	-	UL-CSA-CE
FTEC20(*)5(***)-115SB	Fan Filter		115 AC			80-135	60-100	UL-CSA-CE
FTEC20(*)5(***)-230SB			230 AC			80-135	60-100	UL-CSA-CE
FTEC20(*)5(***)-(**)SB			12/24/48 DC	76-128	57-97	UL-CSA-CE		
FTEC26(*)4X	Exhaust Filter		10-260X260	-	TYPE 12	IP 54	-	-
FTEC26(*)4X-115SBS	Fan Filter	115 AC		137-230			120-205	UL-CSA-CE
FTEC26(*)4X-230SBS		230 AC		137-230			120-205	UL-CSA-CE
FTEC26(*)4X-(**)SBS		12/24/48 DC		130-220			115-195	UL-CSA-CE
FTEC26(*)4X-115SB		115 AC		165-280			147-250	UL-CSA-CE
FTEC26(*)4X-230SB		230 AC		165-280			147-250	UL-CSA-CE
FTEC26(*)4X-(**)SB		12/24/48 DC		170-290	150-255	UL-CSA-CE		
FTEC26(*)4X-115SBB	115 AC	230-390		182-310	UL-CSA-CE			
FTEC26(*)4X-230SBB	230 AC	230-390		182-310	UL-CSA-CE			
FTEC26(*)5(***)	Exhaust Filter	-		TYPE 12 or TYPE 3R	IP 55	-	-	UL-CSA-CE
FTEC26(*)5(***)-115SBS	Fan Filter	115 AC				130-220	100-170	UL-CSA-CE
FTEC26(*)5(***)-230SBS		230 AC				130-220	100-170	UL-CSA-CE
FTEC26(*)5(***)-(**)SBS		12/24/48 DC				117-200	105-180	UL-CSA-CE
FTEC26(*)5(***)-115SB		115 AC				150-255	130-220	UL-CSA-CE
FTEC26(*)5(***)-230SB		230 AC				150-255	130-220	UL-CSA-CE
FTEC26(*)5(***)-(**)SB		12/24/48 DC		155-265	137-230	UL-CSA-CE		
FTEC26(*)5(***)-115SBB	115 AC	190-325		153-260	UL-CSA-CE			
FTEC26(*)5(***)-230SBB	230 AC	190-325		153-260	UL-CSA-CE			
FTEC32(*)4X	Exhaust Filter	12-326X326	-	TYPE 12	IP 54	-	-	UL-CSA-CE
FTEC32(*)4X-115SB	Fan Filter		115 AC			380-645	220-375	UL-CSA-CE
FTEC32(*)4X-230SB			230 AC			380-645	220-375	UL-CSA-CE
FTEC32(*)4X-(**)SB			48 DC			550-935	330-560	UL-CSA-CE
FTEC32(*)4X-115SBB			115 AC			450-765	290-492	UL-CSA-CE
FTEC32(*)4X-230SBB			230 AC			450-765	290-492	UL-CSA-CE
FTEC32(*)4X-115SBG			115 AC	625-1060	430-730	UL-CSA-CE		
FTEC32(*)4X-230SBG	230 AC		625-1060	430-730	UL-CSA-CE			
FTEC32(*)4X-440SBG	460 AC		625-1060	430-730	UL-CSA-CE			
FTEC32(*)5(***)	Exhaust Filter		-	TYPE 12 or TYPE 3R	IP 55	-	-	UL-CSA-CE
FTEC32(*)5(***)-115SB	Fan Filter		115 AC			350-595	190-320	UL-CSA-CE
FTEC32(*)5(***)-230SB			230 AC			350-595	190-320	UL-CSA-CE
FTEC32(*)5(***)-(**)SB		48 DC	500-850			280-475	UL-CSA-CE	
FTEC32(*)5(***)-115SBB		115 AC	418-712			235-400	UL-CSA-CE	
FTEC32(*)5(***)-230SBB		230 AC	418-712			235-400	UL-CSA-CE	
FTEC32(*)5(***)-115SBG		115 AC	595-1010	420-715	UL-CSA-CE			
FTEC32(*)5(***)-230SBG	230 AC	595-1010	420-715	UL-CSA-CE				
FTEC32(*)5(***)-440SBG	460 AC	595-1010	420-715	UL-CSA-CE				

Note: Reverse Flow Fan Filter data is identical to Standard Flow Fan Filters

(*) L means RAL 7035 Light Grey, D means RAL 7032 Dark Grey, B means RAL 9011 Black, and O means Optional colors.

(**) 12D means 12 VDC, 24D means 24 VDC, and 48D means 48 VDC.

(***) X represents Type 12, IP 54 or IP 55 and Z represents Type 3R, IP 55, all airflow is at 60 Hz.



FTEC 10 SERIES

FTEC10 series Performance Chart - 4" Fan Filter and Exhaust Filter

NEMA Rating	Type 12			Type 12 or Type 3R		
	IP 54			IP 55		
Filter Media	G3			G4		
Rated Voltage	100-120 VAC	200-240 VAC	12/24/48 VDC	100-120 VAC	200-240 VAC	12/24/48 VDC
Frequency	60/50 Hz		60/50 Hz	60/50 Hz		60/50 Hz
Bearing	Two Ball Bearing	Two Ball Bearing	Two Ball Bearing	Two Ball Bearing	Two Ball Bearing	Two Ball Bearing
Power connection	3 Poles screwless connector or 2 Pin terminal			3 Poles screwless connector or 2 Pin terminal		
Fan Filters						
RAL 7035 Light Gray	FTEC10L4X-115SB	FTEC10L4X-230SB	FTEC10L4X-(-)DSB	FTEC10L5(**)-115SB	FTEC10L5(**)-230SB	FTEC10L5(**)-(-)DSB
RAL 7032 Dark Gray	FTEC10D4X-115SB	FTEC10D4X-230SB	FTEC10D4X-(-)DSB	FTEC10D5(**)-115SB	FTEC10D5(**)-230SB	FTEC10D5(**)-(-)DSB
RAL 9011 Black	FTEC10B4X-115SB	FTEC10B4X-230SB	FTEC10B4X-(-)DSB	FTEC10B5(**)-115SB	FTEC10B5(**)-230SB	FTEC10B5(**)-(-)DSB
Reverse Flow Fan Filter	FTEC10L4X-115RB	FTEC10L4X-230RB	FTEC10L4X-(-)DRB	FTEC10L5(**)-115RB	FTEC10L5(**)-230RB	FTEC10L5(**)-(-)DRB
Flow Capacity (CFM-m³/hr at 60/50 Hz) and Maximum Static Pressure (in H ₂ O-Pa at 60/50 Hz)						
Unimpeded (***)	15/14 CFM-26/24 m³/hr		38 CFM- 65 m³/hr	14/11 CFM-24/19 m³/hr		35 CFM-60 m³/hr
In combination						
Fan Filter+Exhaust Filter	11/9 CFM-19/16 m³/hr	11/9 CFM -19/16 m³/hr	26 CFM- 45 m³/hr	10/8 CFM -17/14 m³/hr	10/8 CFM -17/14 m³/hr	22 CFM-37 m³/hr
Max. Static Pressure	0.18/0.13-46/33		0.32-80	0.15/0.12-37/30		0.30-75
Fan Filter+Reverse Flow Fan Filter	13/12 CFM-22/20 m³/hr	13/12 CFM-22/20 m³/hr	35 CFM-60 m³/hr	12/11 CFM-20/19 m³/hr	12/11 CFM-20/19 m³/hr	32 CFM-55 m³/hr
Max. Static Pressure	0.20/0.16-50/40		0.34-85	0.18/0.14-46/35		0.31-78
Other Fan Filters Data						
Power Input	9/12 W		2.2/2.9/3.8 W	9/12 W		2.2/2.9/3.8 W
Weight	550 gram /1.21 lb		230 gram /0.51 lb	550 gram /1.21 lb		230 gram /0.51 lb
Noise Level	38/33 dB (A)		55 dB (A)	38/33 dB (A)		55 dB (A)
Durability	50,000 @ 25 °C		60,000 @ 45 °C	50,000 @ 25 °C		60,000 @ 45 °C
Operating Temperature	-20 to +70 °C / -4 to +158 °F			-20 to +70 °C / -4 to +158 °F		
Dimensions	4.57" X 4.57" X 2.95" / 116 X 116 X 75 mm³			4.57" X 4.57" X 2.95" / 116 X 116 X 75 mm³		
Certificates	CSA-UL-CE			CSA-UL-CE		
Exhaust Filter						
	Type 12-IP 54			Type 12 or Type 3R-IP55		
RAL 7035 Light Gray	FTEC10L4X			FTEC10L5(**)		
RAL 7032 Dark Gray	FTEC10D4X			FTEC10D5(**)		
RAL 9011 Black	FTEC10B4X			FTEC10B5(**)		
Dimensions	4.57" X 4.57" X 1.22" / 116 X 116 X 31 mm³			4.57" X 4.57" X 1.22" / 116 X 116 X 31 mm³		
Weight	100 gram / 0.22 lb			100 gram / 0.22 lb		
Certificates	CSA-UL-CE			CSA-UL-CE		
Accessories						
Replacement Filter Media	FTEC10-FM-4			FTEC10-FM-5		
NO Thermostat (°C)	TTEC-200-C / ETEC-400		ETEC-400	TTEC-200-C / ETEC-400		ETEC-400
NO Thermostat (°F)	TTEC-200-F / ETEC-400		ETEC-400	TTEC-200-F / ETEC-400		ETEC-400

(*) 12 means 12 VDC, 24 means 24 VDC, and 48 means 48 VDC

(***) Flow capacity at 90 VAC - 60 Hz (Type 12) is 13.5 CFM

(**) X represents Type 12, IP 54 or IP 55, Z represents Type 3R IP 55

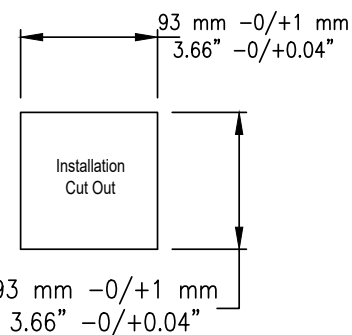
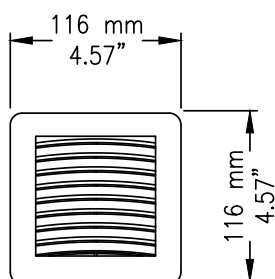
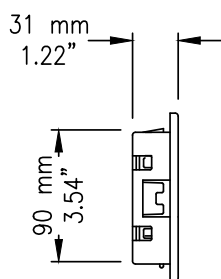
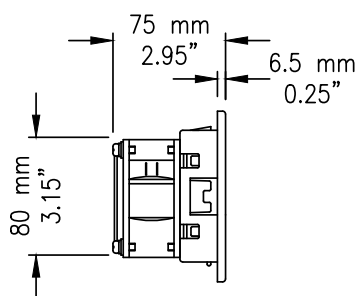
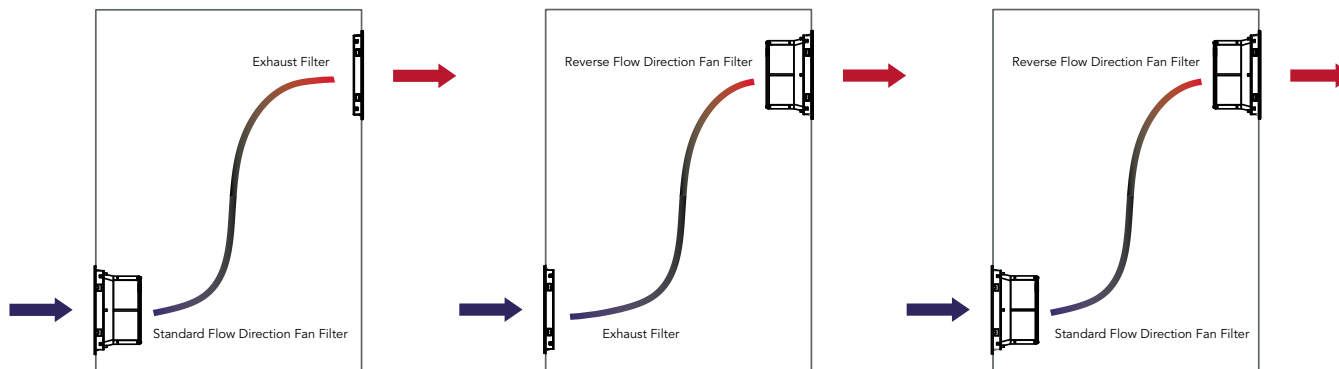

FTEC10L4X-115SB/FTEC10L4X-230SB

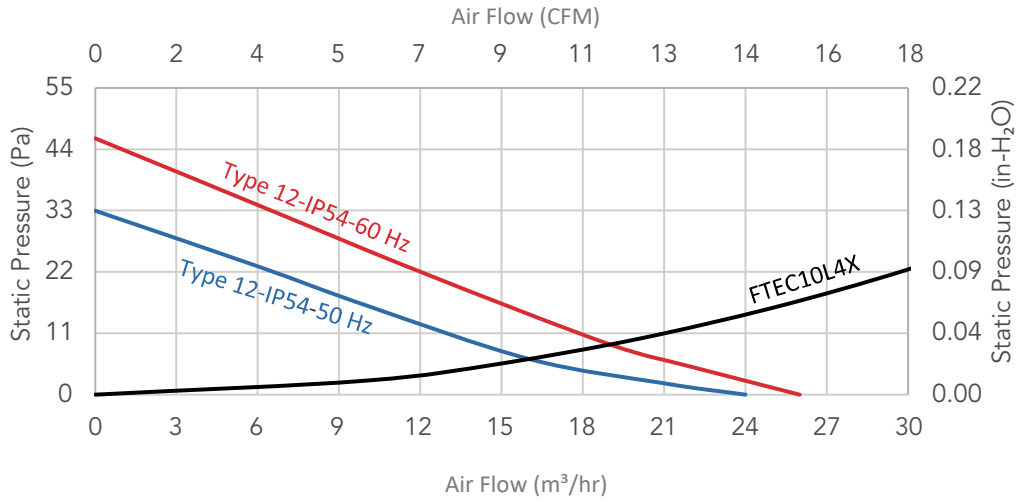

FTEC10L5()-115SB/FTEC10L5(**)-230SB**

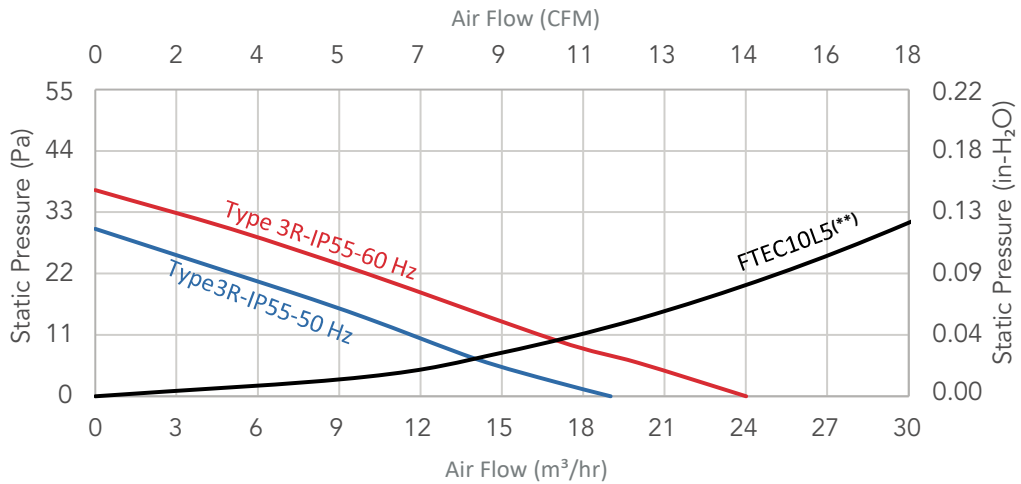

FTEC10L4X-48DSB/FTEC10L5()-48DSB**

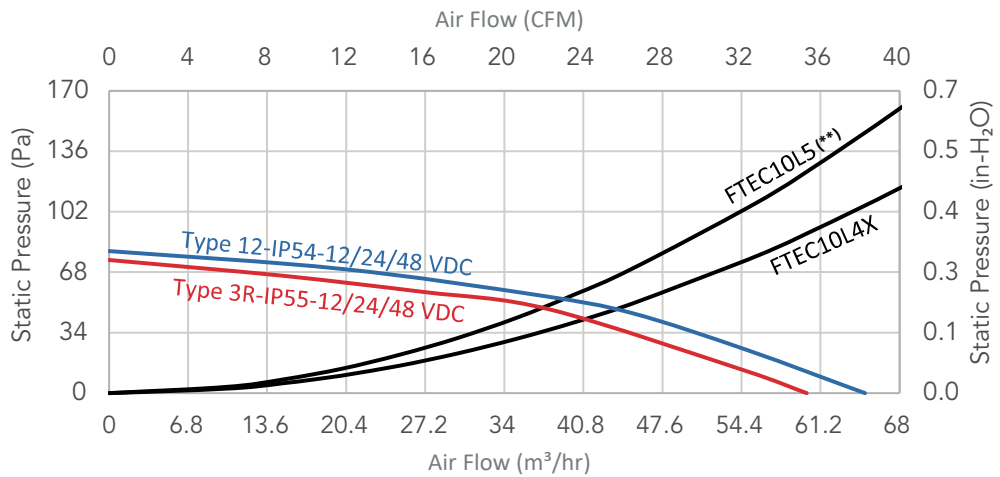

FTEC 16 SERIES

FTEC16 series Performance Chart - 6" Fan Filter and Exhaust Filter

NEMA Rating	Type 12			Type 12 or Type 3R		
IP Rating	IP 54			IP 55		
Filter Media	G3			G4		
Rated Voltage	100-120 VAC	200-240 VAC	12/24/48 VDC	100-120 VAC	200-240 VAC	12/24/48 VDC
Frequency	60/50 Hz	60/50 Hz		60/50 Hz	60/50 Hz	
Bearing	Two Ball Bearing	Two Ball Bearing	Two Ball Bearing	Two Ball Bearing	Two Ball Bearing	Two Ball Bearing
Power connection	3 Poles screwless connector or 2 Pin terminal		Wires	3 Poles screwless connector or 2 Pin terminal		Wires
Fan Filters						
RAL 7035 Light Gray	FTEC16L4X-115SB	FTEC16L4X-230SB	FTEC16L4X-(-)DSB	FTEC16L5(**)-115SB	FTEC16L5(**)-230SB	FTEC16L5(**)-(-)DSB
RAL 7032 Dark Gray	FTEC16D4X-115SB	FTEC16D4X-230SB	FTEC16D4X-(-)DSB	FTEC16D5(**)-115SB	FTEC16D5(**)-230SB	FTEC16D5(**)-(-)DSB
RAL 9011 Black	FTEC16B4X-115SB	FTEC16B4X-230SB	FTEC16B4X-(-)DSB	FTEC16B5(**)-115SB	FTEC16B5(**)-230SB	FTEC16B5(**)-(-)DSB
Reverse Flow Fan Filter	FTEC16L4X-115RB	FTEC16L4X-230RB	FTEC16L4X-(-)DRB	FTEC16L5(**)-115RB	FTEC16L5(**)-230RB	FTEC16L5(**)-(-)DRB
Flow Capacity (CFM-m³/hr at 60/50 Hz) and Maximum Static Pressure (in H₂O-Pa at 60/50 Hz)						
Unimpeded (***)	42/40 CFM-70/68 m³/hr	42/40 CFM-70/68 m³/hr	42 CFM-70 m³/hr	35/31 CFM-60/52 m³/hr	35/31 CFM-60/52 m³/hr	35 CFM-60 m³/hr
In combination						
Fan Filter+Exhaust Filter	35/32 CFM-60/55 m³/hr	35/32 CFM-60/55 m³/hr	35 CFM-60 m³/hr	30/28 CFM-50/47 m³/hr	30/28 CFM-50/47 m³/hr	30 CFM-50 m³/hr
Max. Static Pressure	0.32/0.28-80/70	0.32/0.28-80/70	0.38-95	0.30/0.27-75/68	0.30/0.27-75/68	0.30-75
Fan Filter+Reverse Flow Fan Filter	40/37 CFM-68/63 m³/hr	40/37 CFM-68/63 m³/hr	40 CFM-68 m³/hr	33/30 CFM-56/50 m³/hr	33/30 CFM-56/50 m³/hr	33 CFM-56 m³/hr
Max. Static Pressure	0.34/0.32-84/80	0.34/0.32-84/80	0.34-85	0.32/0.30-80/75	0.32/0.30-80/75	0.32-80
Other Fan Filters Data						
Power Input	17/20 W	17/20 W	10.6/10.3/10.6 W	17/20 W	17/20 W	10.6/10.3/10.6 W
Weight	850 gram/1.87 lb		510 gram/1.21 lb	850 gram/1.87 lb		510 gram/1.21 lb
Noise Level	45/41 dB (A)		50 dB (A)	45/41 dB (A)		50 dB (A)
Durability	50,000 @ 25 °C	50,000 @ 25 °C	60,000 @ 45 °C	50,000 @ 25 °C	50,000 @ 25 °C	60,000 @ 45 °C
Operating Temperature	-20 to +70 °C / -4 to +158 °F			-20 to +70 °C / -4 to +158 °F		
Dimensions	6.3" X 6.3" X 3.01" / 160 X 160 X 76.5 mm³			6.3" X 6.3" X 3.01" / 160 X 160 X 76.5 mm³		
Certificates	CSA-UL-CE			CSA-UL-CE		
Exhaust Filter						
	Type 12-IP 54			Type 12 or Type 3R-IP55		
RAL 7035 Light Gray	FTEC16L4X			FTEC16L5(**)		
RAL 7032 Dark Gray	FTEC16D4X			FTEC16D5(**)		
RAL 9011 Black	FTEC16B4X			FTEC16B5(**)		
Dimensions	6.3" X 6.3" X 1.22" / 160 X 160 X 31 mm³			6.3" X 6.3" X 1.22" / 160 X 160 X 31 mm³		
Weight	200 gram / 0.44 lb			200 gram / 0.44 lb		
Certificates	CSA-UL-CE			CSA-UL-CE		
Accessories						
Replacement Filter Media	FTEC16-FM-4			FTEC16-FM-5		
NO Thermostat (°C)	TTEC-200-C / ETEC-400		ETEC-400	TTEC-200-C / ETEC-400		ETEC-400
NO Thermostat (°F)	TTEC-200-F / ETEC-400		ETEC-400	TTEC-200-F / ETEC-400		ETEC-400

(*) 12 means 12 VDC, 24 means 24 VDC, and 48 means 48 VDC

(**) Flow capacity at 90 VAC - 60 Hz (Type 12) is 35 CFM

(**) X represents Type 12, IP 54 or IP 55, Z represents Type 3R IP 55

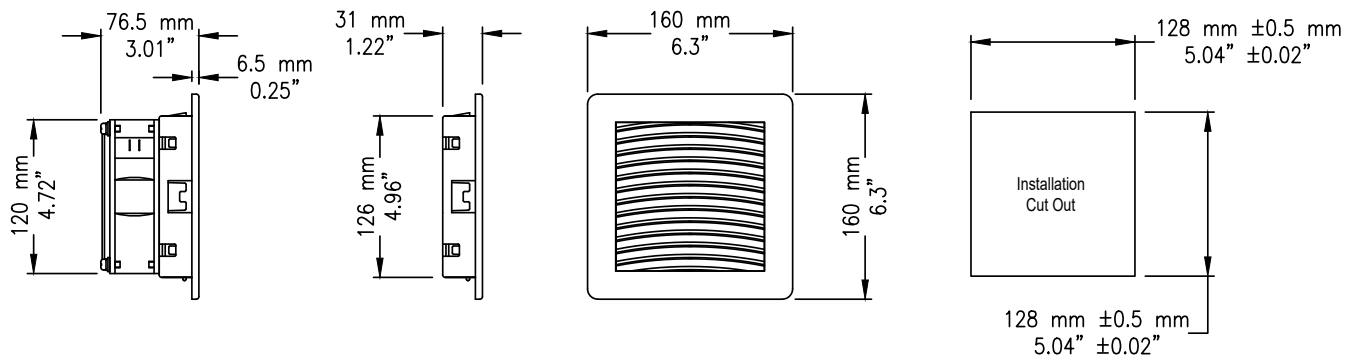
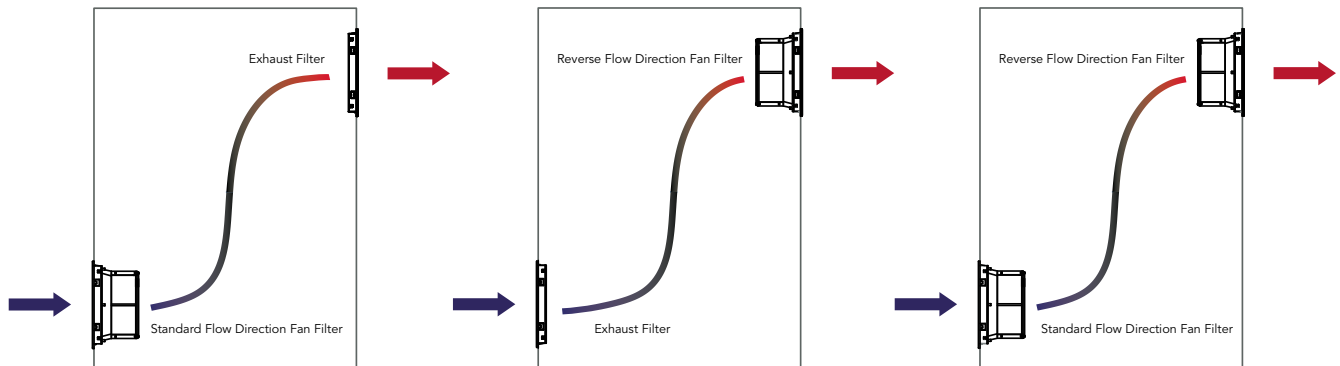

FTEC16L4X-115SB/FTEC16L4X-230SB

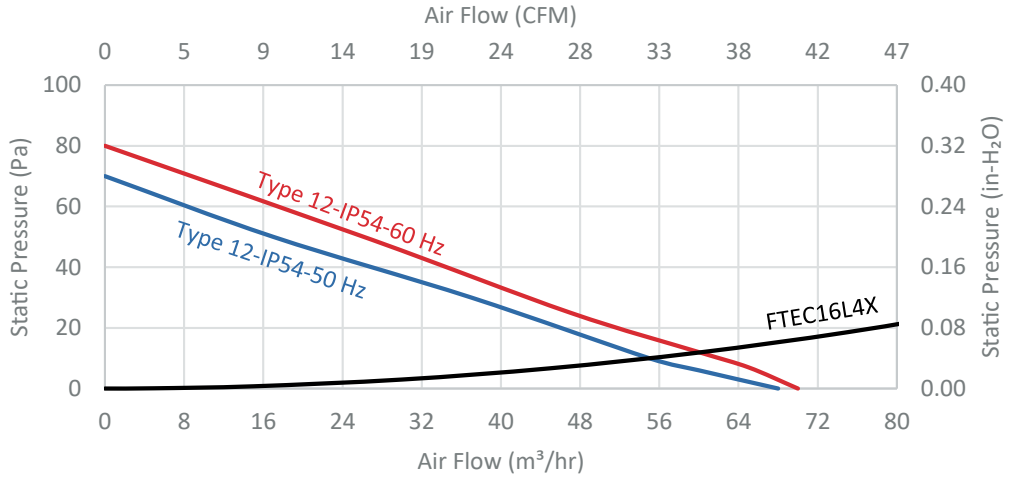

FTEC16L5()-115SB/FTEC16L5(**)-230SB**

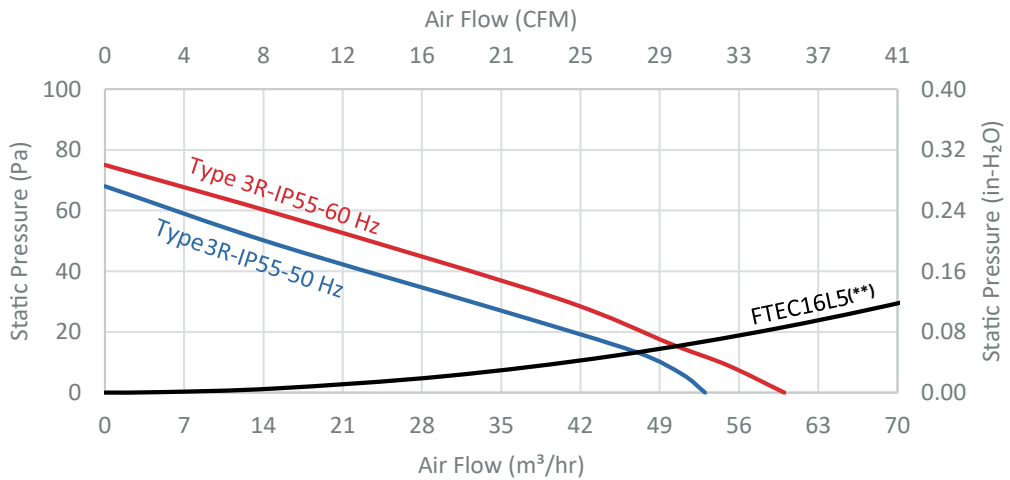

FTEC16L4X-48DSB/FTEC16L5()-48DSB**

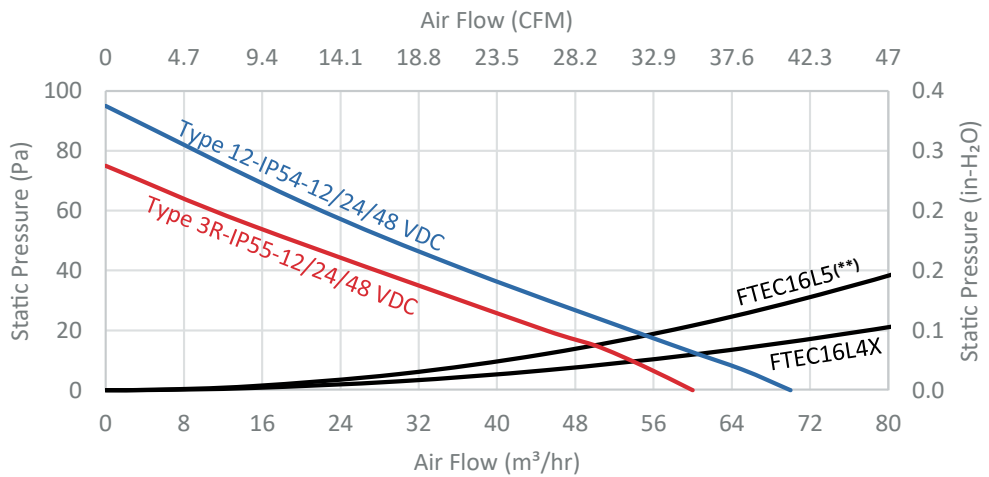

FTEC 20 SERIES

FTEC20 series Performance Chart - 8" Fan Filter and Exhaust Filter

NEMA Rating	Type 12			Type 12 or Type 3R		
	IP 54			IP 55		
Filter Media	G3					
Rated Voltage	100-120 VAC	200-240 VAC	12/24/48 VDC	100-120 VAC	200-240 VAC	12/24/48 VDC
Frequency	60/50 Hz	60/50 Hz		60/50 Hz	60/50 Hz	
Bearing	Two Ball Bearing	Two Ball Bearing	Two Ball Bearing	Two Ball Bearing	Two Ball Bearing	Two Ball Bearing
Power connection	3 Poles screwless connector or 2 Pin terminal			3 Poles screwless connector or 2 Pin terminal		
Fan Filters						
RAL 7035 Light Gray	FTEC20L4X-115SB	FTEC20L4X-230SB	FTEC20L4X-(-)DSB	FTEC20L5(**)-115SB	FTEC20L5(**)-230SB	FTEC20L5(**)-(-)DSB
RAL 7032 Dark Gray	FTEC20D4X-115SB	FTEC20D4X-230SB	FTEC20D4X-(-)DSB	FTEC20D5(**)-115SB	FTEC20D5(**)-230SB	FTEC20D5(**)-(-)DSB
RAL 9011 Black	FTEC20B4X-115SB	FTEC20B4X-230SB	FTEC20B4X-(-)DSB	FTEC20B5(**)-115SB	FTEC20B5(**)-230SB	FTEC20B5(**)-(-)DSB
Reverse Flow Fan Filter	FTEC20L4X-115RB	FTEC20L4X-230RB	FTEC20L4X-(-)DRB	FTEC20L5(**)-115RB	FTEC20L5(**)-230RB	FTEC20L5(**)-(-)DRB
Flow Capacity (CFM-m³/hr at 60/50 Hz) and Maximum Static Pressure (in H₂O-Pa at 60/50 Hz)						
Unimpeded (***)	95/90 CFM-160/152 m³/hr	95/90 CFM-160/152 m³/hr	90 CFM-152 m³/hr	80/76 CFM-135/128 m³/hr	80/76 CFM-135/128 m³/hr	76 CFM-128 m³/hr
In combination						
Fan Filter+Exhaust Filter	70/65 CFM-120/110 m³/hr	70/65 CFM-120/110 m³/hr	70 CFM-120 m³/hr	60/55 CFM-100/95 m³/hr	60/55 CFM-100/95 m³/hr	57 CFM-97 m³/hr
Max. Static Pressure	0.36/0.33-90/82	0.36/0.33-90/82	0.37-92	0.33/0.30-82/75	0.33/0.30-82/75	0.34-85
Fan Filter+Reverse Flow Fan Filter	80/75 CFM-135/127 m³/hr	80/75 CFM-135/127 m³/hr	77 CFM-130 m³/hr	70/65 CFM-120/110 m³/hr	70/65 CFM-120/110 m³/hr	67 CFM-115 m³/hr
Max. Static Pressure	0.39/0.34-96/85	0.39/0.34-96/85	0.40-100	0.35/0.33-87/82	0.35/0.33-87/82	0.36-90
Other Fan Filters Data						
Power Input	17/20 W	17/20 W	10.6/10.3/10.6 W	17/20 W	17/20 W	10.6/10.3/10.6 W
Weight	950 gram / 2.1 lb		610 gram / 1.35 lb	950 gram / 2.1 lb		610 gram / 1.35 lb
Noise Level	45/41 dB (A)		50 dB (A)	45/41 dB (A)		50 dB (A)
Durability	50,000 @ 25 °C	50,000 @ 25 °C	60,000 @ 45 °C	50,000 @ 25 °C	50,000 @ 25 °C	60,000 @ 45 °C
Operating Temperature	-20 to +70 °C / -4 to +158 °F			-20 to +70 °C / -4 to +158 °F		
Dimensions	8.11" X 8.11" X 4.41" / 206 X 206 X 112 mm³			8.11" X 8.11" X 4.41" / 206 X 206 X 112 mm³		
Certificates	CSA-UL-CE			CSA-UL-CE		
Exhaust Filter						
	Type 12-IP 54			Type 12 or Type 3R-IP55		
RAL 7035 Light Gray	FTEC20L4X			FTEC20L5(**)		
RAL 7032 Dark Gray	FTEC20D4X			FTEC20D5(**)		
RAL 9011 Black	FTEC20B4X			FTEC20B5(**)		
Dimensions	8.11" X 8.11" X 1.22" / 206 X 206 X 31 mm³			8.11" X 8.11" X 1.22" / 206 X 206 X 31 mm³		
Weight	300 gram / 0.66 lb			300 gram / 0.66 lb		
Certificates	CSA-UL-CE			CSA-UL-CE		
Accessories						
Replacement Filter Media	FTEC20-FM-4			FTEC20-FM-5		
NO Thermostat (°C)	TTEC-200-C / ETEC-400		ETEC-400	TTEC-200-C / ETEC-400		ETEC-400
NO Thermostat (°F)	TTEC-200-F / ETEC-400		ETEC-400	TTEC-200-F / ETEC-400		ETEC-400

(*) 12 means 12 VDC, 24 means 24 VDC, and 48 means 48 VDC

(***) Flow capacity at 90 VAC - 60 Hz (Type 12) is 80 CFM

(**) X represents Type 12, IP 54 or IP 55, Z represents Type 3R IP 55

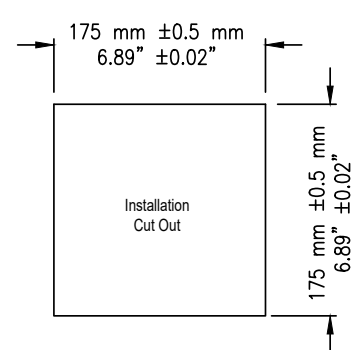
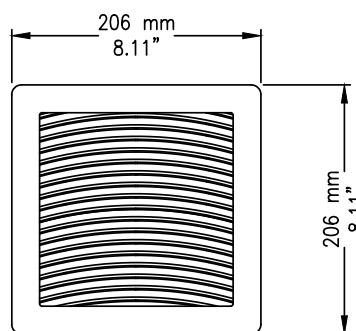
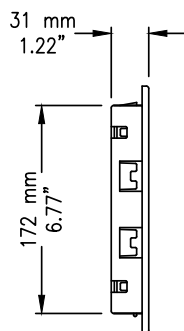
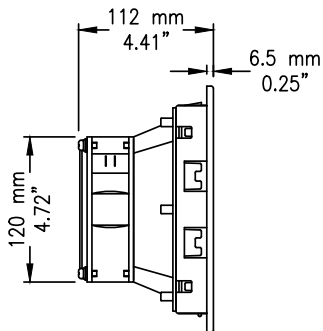
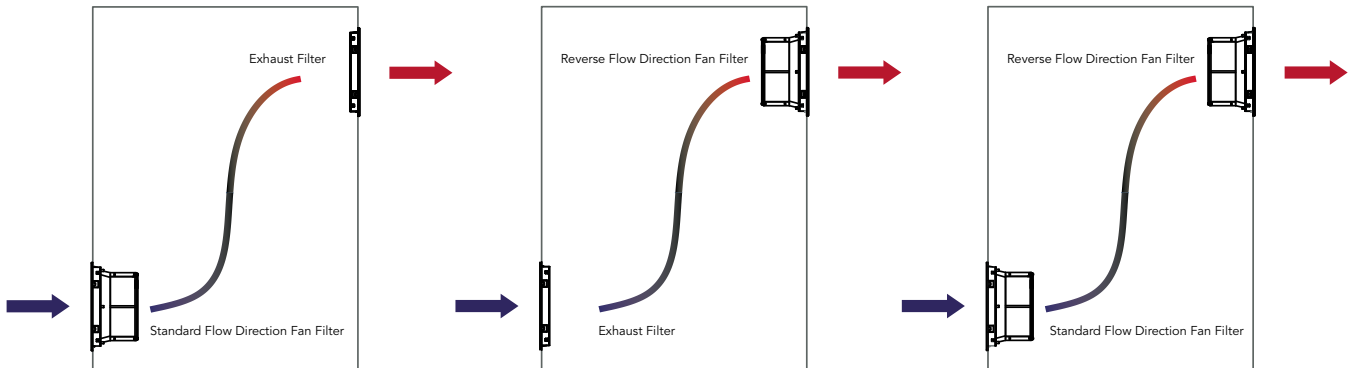

FTEC20L4X-115SB/FTEC20L4X-230SB

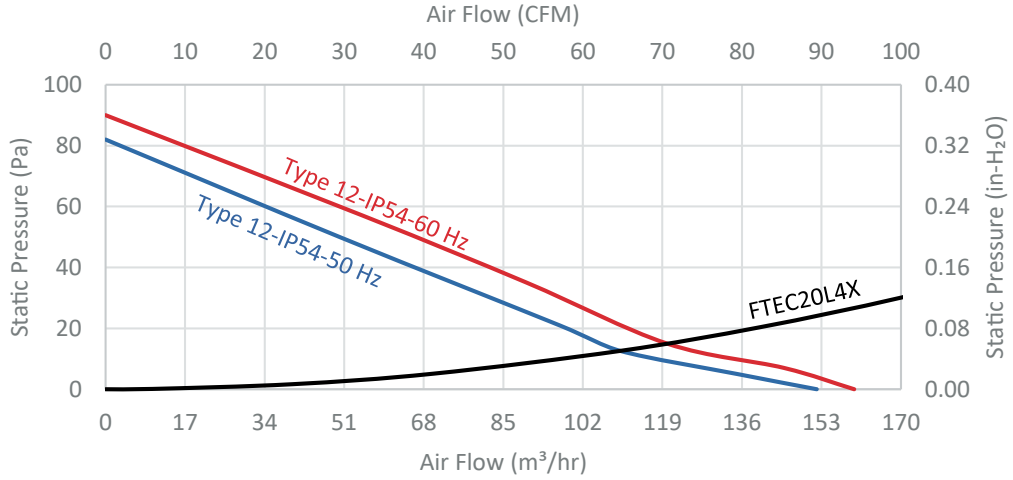

FTEC20L5()-115SB/FTEC20L5(**)-230SB**

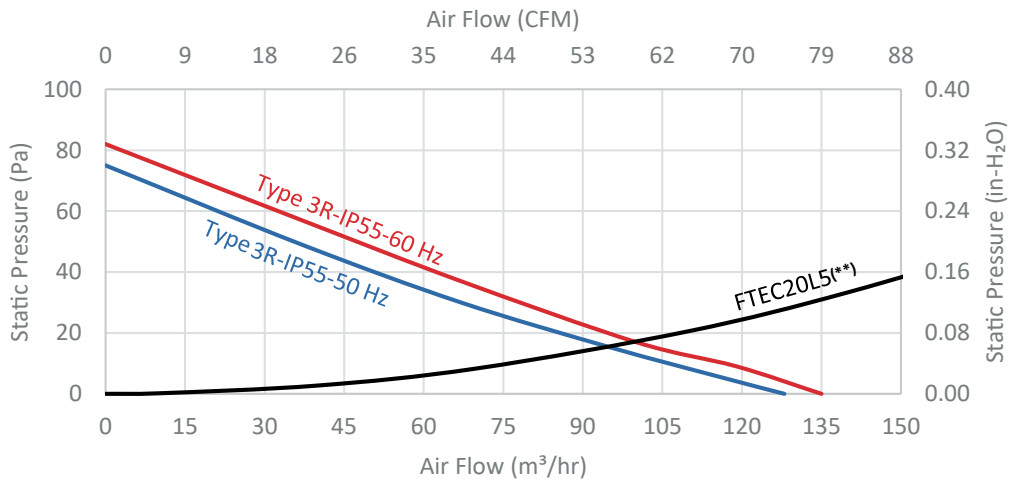

FTEC20L4X-48DSB/FTEC20L5()-48DSB**

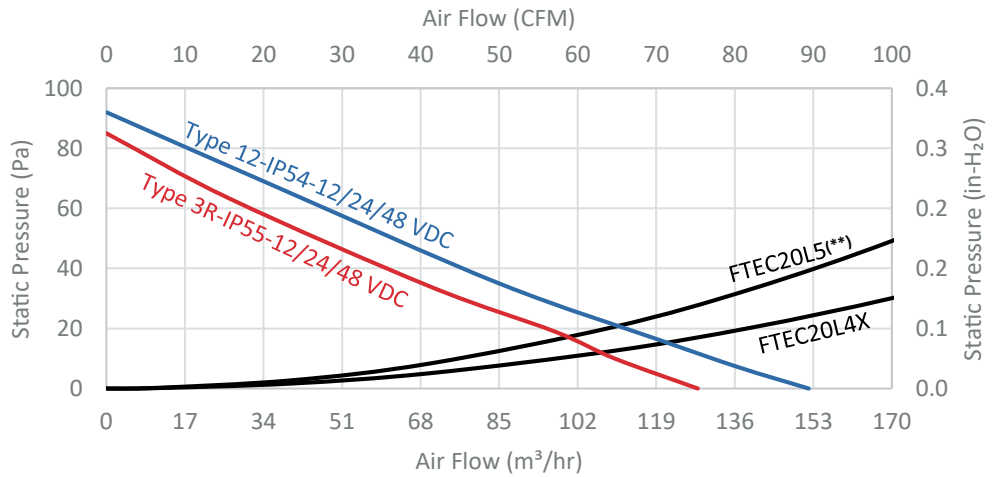

FTEC 26S SERIES

FTEC26S series Performance Chart - 10" Fan Filter and Exhaust Filter

NEMA Rating	Type 12			Type 12 or Type 3R		
	IP 54			IP 55		
Filter Media	G3					
Rated Voltage	100-120 VAC	200-240 VAC	12/24/48 VDC	100-120 VAC	200-240 VAC	12/24/48 VDC
Frequency	60/50 Hz	60/50 Hz		60/50 Hz	60/50 Hz	
Bearing	Two Ball Bearing	Two Ball Bearing	Two Ball Bearing	Two Ball Bearing	Two Ball Bearing	Two Ball Bearing
Power connection	3 Poles screwless connector or 2 Pin terminal			3 Poles screwless connector or 2 Pin terminal		
Fan Filters						
RAL 7035 Light Gray	FTEC26L4X-115SBS	FTEC26L4X-230SBS	FTEC26L4X-(*)DSBS	FTEC26L5(**)-115SBS	FTEC26L5(**)-230SBS	FTEC26L5(**)-(*)DSBS
RAL 7032 Dark Gray	FTEC26D4X-115SBS	FTEC26D4X-230SBS	FTEC26D4X-(*)DSBS	FTEC26D5(**)-115SBS	FTEC26D5(**)-230SBS	FTEC26D5(**)-(*)DSBS
RAL 9011 Black	FTEC26B4X-115SBS	FTEC26B4X-230SBS	FTEC26B4X-(*)DSBS	FTEC26B5(**)-115SBS	FTEC26B5(**)-230SBS	FTEC26B5(**)-(*)DSBS
Reverse Flow Fan Filter	FTEC26L4X-115RBS	FTEC26L4X-230RBS	FTEC26L4X-(*)DRBS	FTEC26L5(**)-115RBS	FTEC26L5(**)-230RBS	FTEC26L5(**)-(*)DRBS
Flow Capacity (CFM-m³/hr at 60/50 Hz) and Maximum Static Pressure (in H₂O-Pa at 60/50 Hz)						
Unimpeded (***)	137/130CFM-230/220m ³ /hr	137/130CFM-230/220m ³ /hr	130 CFM-220 m ³ /hr	130/125 CFM-220/210 m ³ /hr	130/125 CFM-220/210 m ³ /hr	117 CFM-200 m ³ /hr
In combination						
Fan Filter+Exhaust Filter	120/115CFM-205/195m ³ /hr	120/115CFM-205/195m ³ /hr	115 CFM-195 m ³ /hr	100/95 CFM-170/160 m ³ /hr	100/95 CFM-170/160 m ³ /hr	105 CFM-180 m ³ /hr
Max. Static Pressure	0.37/0.32-92/80	0.37/0.32-92/80	0.34-85	0.34/0.31-85/78	0.34/0.31-85/78	0.32-80
Fan Filter+Reverse Flow Fan Filter	130/125CFM-220/210m ³ /hr	130/125CFM-220/210m ³ /hr	120 CFM-205 m ³ /hr	120/115 CFM-205/195 m ³ /hr	120/115 CFM-205/195 m ³ /hr	107 CFM-182 m ³ /hr
Max. Static Pressure	0.40/0.36-100/90	0.40/0.36-100/90	0.36-90	0.34/0.31-89/82	0.34/0.31-89/82	0.34-85
Other Fan Filters Data						
Power Input	17/20 W	17/20 W	10.6/10.3/10.6 W	17/20 W	17/20 W	10.6/10.3/10.6 W
Weight	1250 gram / 2.75 lb		910 gram / 2.0 lb	1250 gram / 2.75 lb		910 gram / 2.0 lb
Noise Level	45/41 dB (A)		50 dB (A)	45/41 dB (A)		50 dB (A)
Durability	50,000 @ 25 °C	50,000 @ 25 °C	65,000 @ 45 °C	50,000 @ 25 °C	50,000 @ 25 °C	65,000 @ 45 °C
Operating Temperature	-20 to +70 °C / -4 to +158 °F			29 to +70 °C / -4 to +158 °F		
Dimensions	10.24" X 10.24" X 4.41" / 260X260X112 mm ³			10.24" X 10.24" X 4.41" / 260X260X112 mm ³		
Certificates	CSA-UL-CE			CSA-UL-CE		
Exhaust Filter						
	Type 12-IP 54			Type 12 or Type 3R-IP55		
RAL 7035 Light Gray	FTEC26L4X			FTEC26L5(**)		
RAL 7032 Dark Gray	FTEC26D4X			FTEC26D5(**)		
RAL 9011 Black	FTEC26B4X			FTEC26B5(**)		
Dimensions	10.24" X 10.24" X 1.22" / 260 X 260 X 31 mm ³			10.24" X 10.24" X 1.22" / 260 X 260 X 31 mm ³		
Weight	450 gram / 1 lb			450 gram / 1 lb		
Certificates	CSA-UL-CE			CSA-UL-CE		
Accessories						
Replacement Filter Media	FTEC26-FM-4			FTEC26-FM-5		
NO Thermostat (°C)	TTEC-200-C/EETEC-400		EETEC-400	TTEC-200-C/EETEC-400		EETEC-400
NO Thermostat (°F)	TTEC-200-F/EETEC-400		EETEC-400	TTEC-200-F/EETEC-400		EETEC-400

(*) 12 means 12 VDC, 24 means 24 VDC, and 48 means 48 VDC

(***) Flow capacity at 90 VAC - 60 Hz (Type 12) is 120 CFM

(**) X represents Type 12, IP 54 or IP 55, Z represents Type 3R IP 55

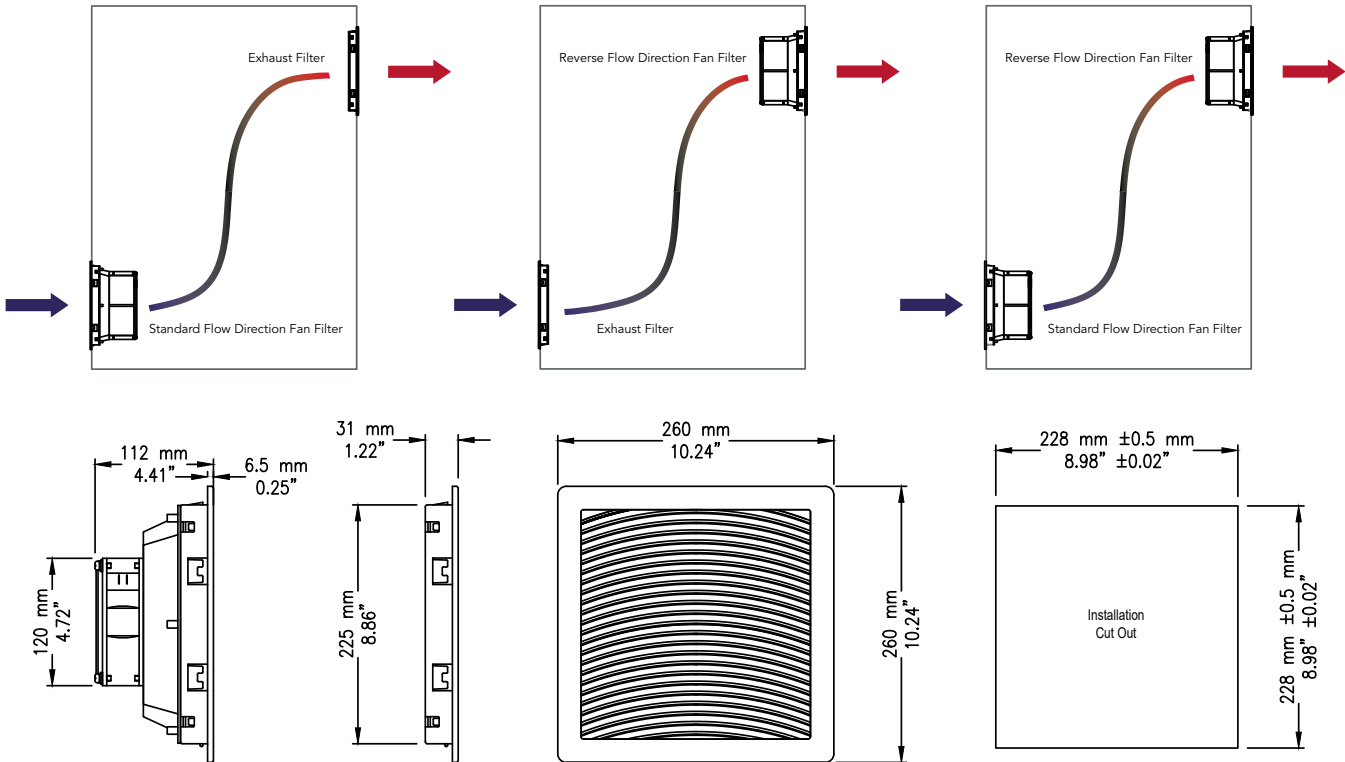

FTEC26L4X-115SBS/FTEC26L4X-230SBS

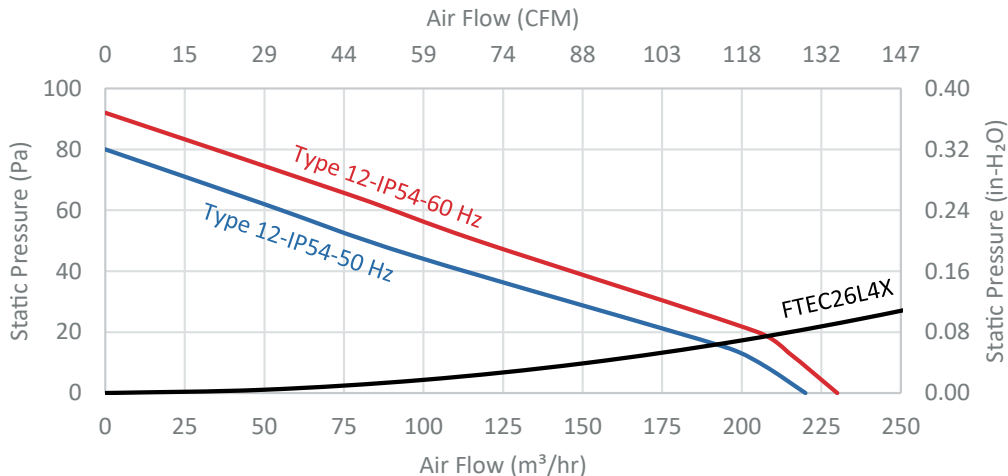

FTEC26L5()-115SBS/FTEC26L5(**)-230SBS**

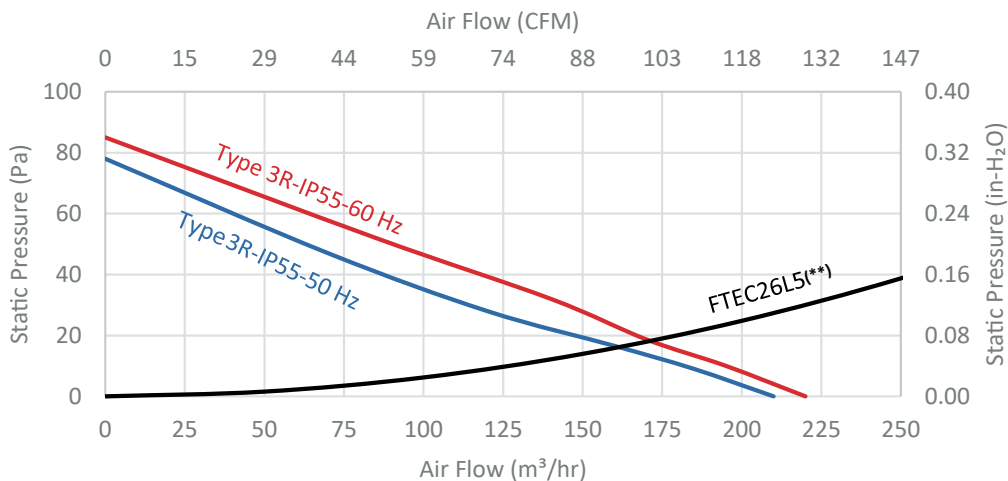

FTEC26L4X-48DSBS/FTEC26L5()-48DSBS**

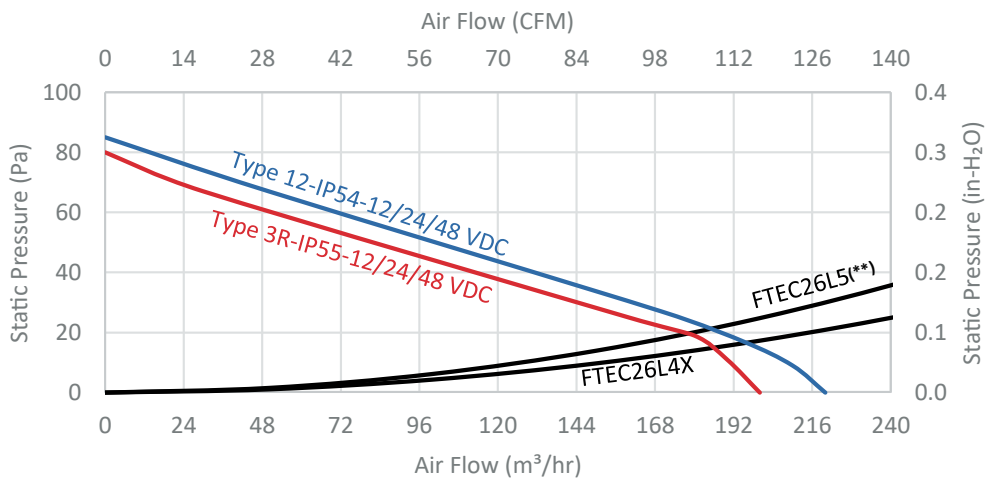

FTEC 26 SERIES

FTEC26 series Performance Chart - 10" Fan Filter and Exhaust Filter

NEMA Rating	Type 12			Type 12 or Type 3R		
	IP 54			IP 55		
Filter Media	G3			G4		
Rated Voltage	100-120VAC	200-240 VAC	12/24/48 VDC	100-120 VAC	200-240 VAC	12/24/48 VDC
Frequency	60/50 Hz	60/50 Hz		60/50 Hz	60/50 Hz	
Bearing	Two Ball Bearing	Two Ball Bearing	Two Ball Bearing	Two Ball Bearing	Two Ball Bearing	Two Ball Bearing
Power connection	3 Poles screwless connector or 2 Pin terminal		Wires	3 Poles screwless connector or 2 Pin terminal		Wires
Fan Filters						
RAL 7035 Light Gray	FTEC26L4X-115SB	FTEC26L4X-230SB	FTEC26L4X-(*)DSB	FTEC26L5(**)-115SB	FTEC26L5(**)-230SB	FTEC26L5(**)-(*)DSB
RAL 7032 Dark Gray	FTEC26D4X-115SB	FTEC26D4X-230SB	FTEC26D4X-(*)DSB	FTEC26D5(**)-115SB	FTEC26D5(**)-230SB	FTEC26D5(**)-(*)DSB
RAL 9011 Black	FTEC26B4X-115SB	FTEC26B4X-230SB	FTEC26B4X-(*)DSB	FTEC26B5(**)-115SB	FTEC26B5(**)-230SB	FTEC26B5(**)-(*)DSB
Reverse Flow Fan Filter	FTEC26L4X-115RB	FTEC26L4X-230RB	FTEC26L4X-(*)DRB	FTEC26L5(**)-115RB	FTEC26L5(**)-230RB	FTEC26L5(**)-(*)DRB
Flow Capacity (CFM-m³/hr at 60/50 Hz) and Maximum Static Pressure (in H₂O-Pa at 60/50 Hz)						
Unimpeded (***)	165/155CFM- 280/265 m ³ /hr	165/155 CFM -280/265m ³ /hr	170 CFM - 290 m ³ /hr	150/140 CFM - 255/237 m ³ /hr	150/140 CFM - 255/237 m ³ /hr	155 CFM-265 m ³ /hr
In combination						
Fan Filter+Exhaust Filter	147/140 CFM - 250/237 m ³ /hr	147/140 CFM - 250/237 m ³ /hr	150 CFM - 255 m ³ /hr	130/125 CFM - 220/212 m ³ /hr	130/125 CFM - 220/212 m ³ /hr	137 CFM-230 m ³ /hr
Max. Static Pressure	0.40/0.35 -100/88	0.40/0.35 - 100/88	0.42/105	0.37/0.34 - 92/85	0.37/0.34-92/85	0.40-100
Fan Filter+Reverse Flow Fan Filter	155/150 CFM- 265/255 m ³ /hr	155/150 CFM - 265/255 m ³ /hr	160 CFM - 270 m ³ /hr	140/133 CFM - 237/225 m ³ /hr	140/133 CFM -237/225 m ³ /hr	147 CFM-250 m ³ /hr
Max. Static Pressure	0.46/0.43 -115/107	0.46/0.43 - 115/107	0.48 -120	0.42/0.40 -105/100	0.42/0.40 -105/100	0.44-110
Other Fan Filters Data						
Power Input	40/43 W	36/38 W	23/24/23.5 W	40/43 W	36/38 W	23/24/23.5 W
Weight	1600 gram /3.53 lb			1600 gram /3.53 lb		
Noise Level	46/58 dB (A)		59 dB (A)	46/58 dB (A)		59 dB (A)
Durability	50,000 @ 25 °C	50,000 @ 25 °C	90,000 @ 35 °C	50,000 @ 25 °C	50,000 @ 25 °C	90,000 @ 35 °C
Operating Temperature	-20 to +70 °C / -4 to +158 °F			-20 to +70°C / -4 to +158 °F		
Dimensions	10.24" X 10.24" X 4.90" / 260X260X124.5 mm ³			10.24" X 10.24" X 4.90" / 260X260X124.5 mm ³		
Certificates	CSA-UL-CE			CSA-UL-CE		
Exhaust Filter						
	Type 12-IP 54			Type 12 or Type 3R-IP55		
RAL 7035 Light Gray	FTEC26L4X			FTEC26L5(**)		
RAL 7032 Dark Gray	FTEC26D4X			FTEC26D5(**)		
RAL 9011 Black	FTEC26B4X			FTEC26B5(**)		
Dimensions	10.24" X 10.24" X 1.22" / 260 X 260 X 31 mm ³			10.24" X 10.24" X 1.22" / 260 X 260 X 31 mm ³		
Weight	450 gram / 1 lb			450 gram / 1 lb		
Certificates	CSA-UL-CE			CSA-UL-CE		
Accessories						
Replacement Filter Media	FTEC26-FM-4			FTEC26-FM-5		
NO Thermostat (°C)	TTEC-200-C /ETEC-400		ETEC-400	TTEC-200-C /ETEC-400		ETEC-400
NO Thermostat (°F)	TTEC-200-F /ETEC-400		ETEC-400	TTEC-200-F /ETEC-400		ETEC-400

(*) 12 means 12 VDC, 24 means 24 VDC, and 48 means 48 VDC

(***) Flow capacity at 90 VAC - 60 Hz (Type 12) is 130 CFM

(**) X represents Type 12, IP 54 or IP 55, Z represents Type 3R IP 55

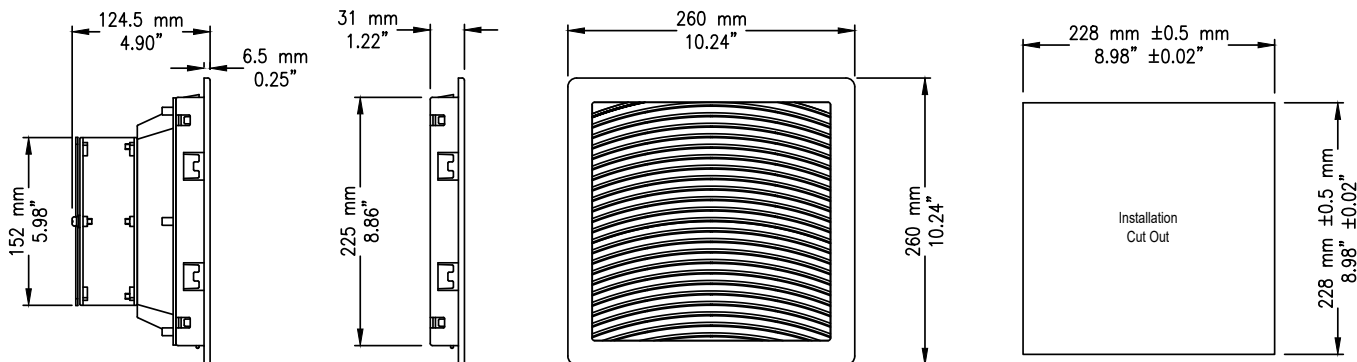
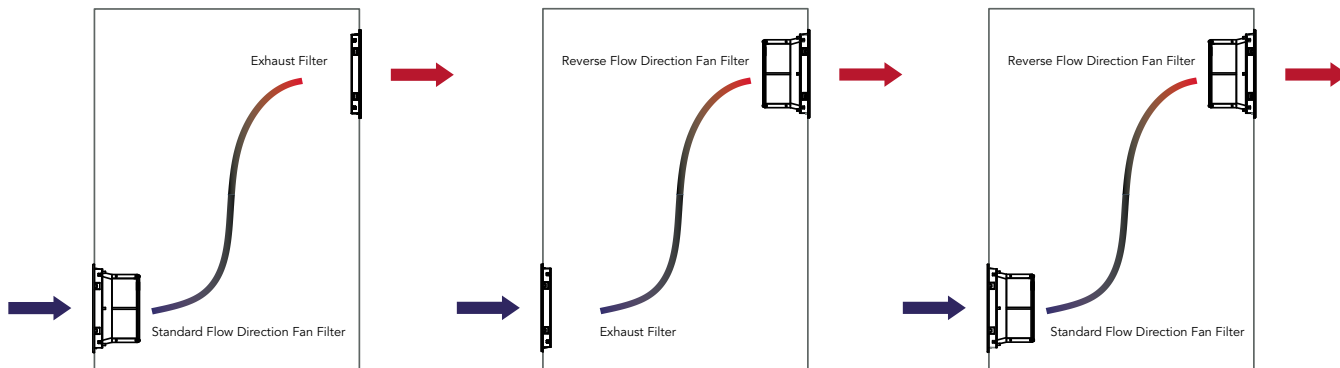

FTEC26L4X-115SB/FTEC26L4X-230SB

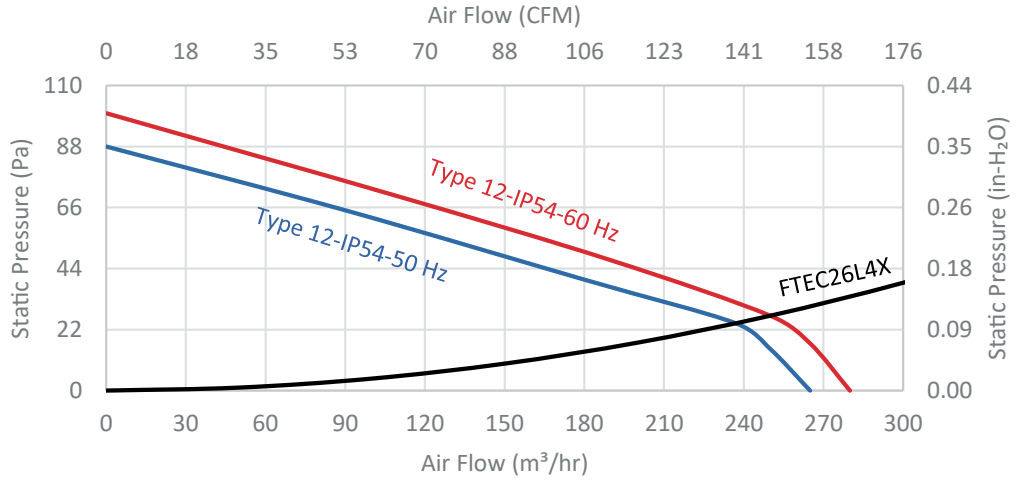

FTEC26L5()-115SB/FTEC26L5(**)-230SB**

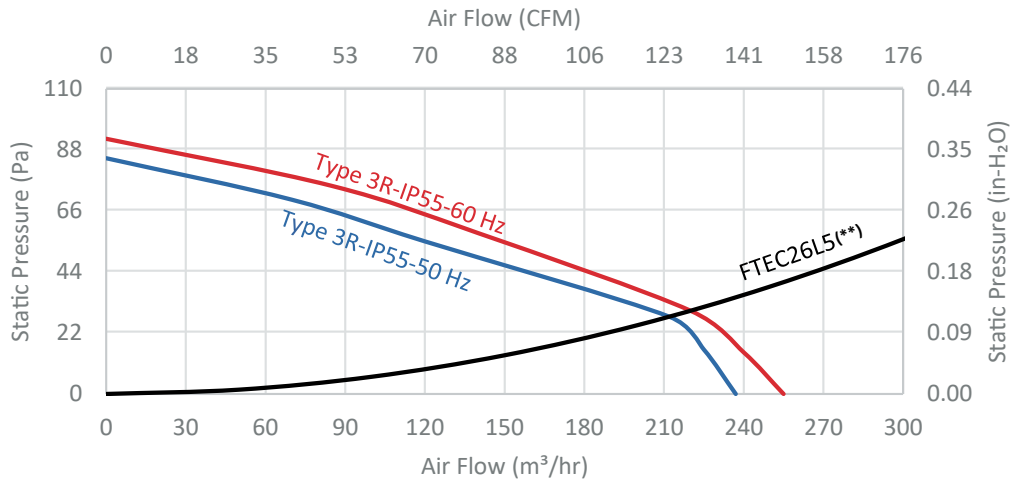

FTEC26L4X-48DSB/FTEC26L5()-48DSB**

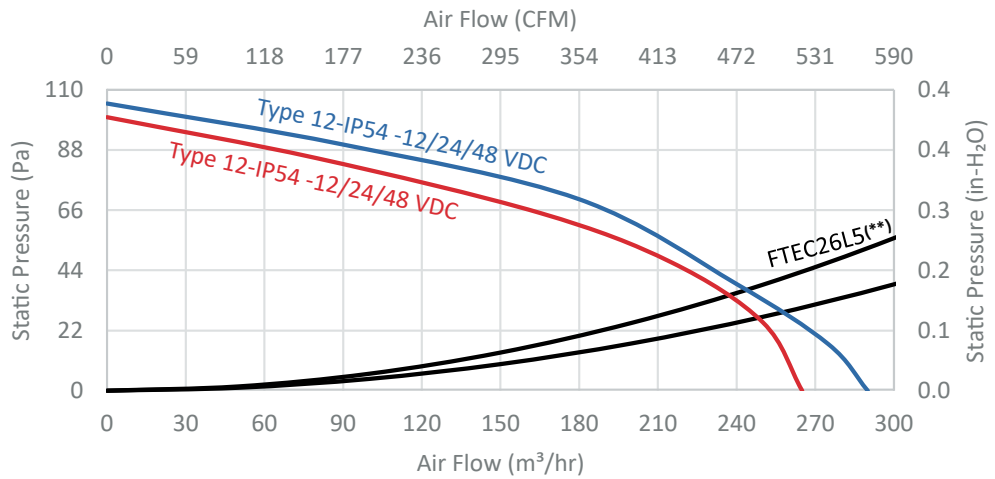

FTEC 26B SERIES

FTEC26B series Performance Chart - 10" Fan Filter and Exhaust Filter

NEMA Rating	Type 12			Type 12 or Type 3R		
	IP 54			IP 55		
Filter Media	G3			G4		
Rated Voltage	100-120 VAC	200-240 VAC	12/24/48 VDC	100-120 VAC	200-240 VAC	12/24/48 VDC
Frequency	60/50 Hz	60/50 Hz		60/50 Hz	60/50 Hz	
Bearing	Two Ball Bearing	Two Ball Bearing	Two Ball Bearing	Two Ball Bearing	Two Ball Bearing	Two Ball Bearing
Power connection	3 Poles screwless connector or 2 Pin terminal			3 Poles screwless connector or 2 Pin terminal		
Fan Filters						
RAL 7035 Light Gray	FTEC26L4X-115SBB	FTEC26L4X-230SBB	FTEC26L4X-(-)DSBB	FTEC26L5(**)-115SBB	FTEC26L5(**)-230SBB	FTEC26L5Z-(-)DSB
RAL 7032 Dark Gray	FTEC26D4X-115SBB	FTEC26D4X-230SBB	FTEC26D4X-(-)DSBB	FTEC26D5(**)-115SBB	FTEC26D5(**)-230SBB	FTEC26D5Z-(-)DSB
RAL 9011 Black	FTEC26B4X-115SBB	FTEC26B4X-230SBB	FTEC26B4X-(-)DSBB	FTEC26B5(**)-115SBB	FTEC26B5(**)-230SBB	FTEC26B5Z-(-)DSB
Reverse Flow Fan Filter	FTEC26L4X-115RBB	FTEC26L4X-230RBB	FTEC26L4X-(-)DRB	FTEC26L5(**)-115RBB	FTEC26L5(**)-230RBB	FTEC26L5Z-(-)DRB
Flow Capacity (CFM-m³/hr at 60/50 Hz) and Maximum Static Pressure (in H₂O-Pa at 60/50 Hz)						
Unimpeded (***)	230/200 CFM-390/340 m ³ /hr	230/200 CFM-390/340 m ³ /hr	170 CFM -290 m ³ /hr	190/170 CFM-325/290 m ³ /hr	190/170 CFM-325/290 m ³ /hr	155 CFM -265 m ³ /hr
In combination						
Fan Filter+Exhaust Filter	182/159 CFM-310/270 m ³ /hr	182/159 CFM-310/270 m ³ /hr	150 CFM-255 m ³ /hr	153/135 CFM-260/230 m ³ /hr	153/135 CFM-260/230 m ³ /hr	137 CFM-230 m ³ /hr
Max. Static Pressure	0.48/0.41-120/102	0.48/0.41-120/102	0.42/105	0.46/0.39-114/96	0.46/0.39-114/96	0.40-100
Fan Filter+Reverse Flow Fan Filter	210/180 CFM-356/306 m ³ /hr	210/180 CFM-356/306 m ³ /hr	160 CFM-270 m ³ /hr	172/155 CFM-292/263 m ³ /hr	172/155 CFM-292/263 m ³ /hr	147 CFM-250 m ³ /hr
Max. Static Pressure	0.55/0.46-137/114	0.55/0.46-137/114	0.48-120	0.53/0.45-132/112	0.53/0.45-132/112	0.44-110
Other Fan Filters Data						
Power Input	35/26 W	35/26 W	23/24/23.5 W	35/26 W	35/26 W	23/24/23.5 W
Weight	1650 gram /3.64 lb		1650 gram /3.64 lb	1650 gram /3.64 lb		1650 gram /3.64 lb
Noise Level	65/60 dB (A)		59 dB (A)	65/60 dB (A)		59 dB (A)
Durability	50,000 @ 55 °C	50,000 @ 55 °C	90,000 @ 35 °C	50,000 @ 55 °C	50,000 @ 55 °C	90,000 @ 35 °C
Operating Temperature	-20 to +70 °C / -4 to +158 °F			-20 to +70 °C / -4 to +158 °F		
Dimensions	10.24" X 10.24" X 4.90" / 260X260X124.5 mm ³			10.24" X 10.24" X 4.90" / 260X260X124.5 mm ³		
Certificates	CSA-UL-CE			CSA-UL-CE		
Exhaust Filter						
	Type 12-IP 54			Type 12 or Type 3R-IP55		
RAL 7035 Light Gray	FTEC26L4X			FTEC26L5(**)		
RAL 7032 Dark Gray	FTEC26D4X			FTEC26D5(**)		
RAL 9011 Black	FTEC26B4X			FTEC26B5(**)		
Dimensions	10.24" X 10.24" X 1.22" / 260 X 260 X 31 mm ³			10.24" X 10.24" X 1.22" / 260 X 260 X 31 mm ³		
Weight	450/1			450/1		
Certificates	CSA-UL-CE			CSA-UL-CE		
Accessories						
Replacement Filter Media	FTEC26-FM-4			FTEC26-FM-5		
NO Thermostat (°C)	TTEC-200-C / ETEC-400		ETEC-400	TTEC-200-C / ETEC-400		ETEC-400
NO Thermostat (°F)	TTEC-200-F / ETEC-400		ETEC-400	TTEC-200-F / ETEC-400		ETEC-400

(*) 12 means 12 VDC, 24 means 24 VDC, and 48 means 48 VDC

(**) Flow capacity at 90 VAC - 60 Hz (Type 12) is 190 CFM

(**) X represents Type 12, IP 54 or IP 55, Z represents Type 3R IP 55

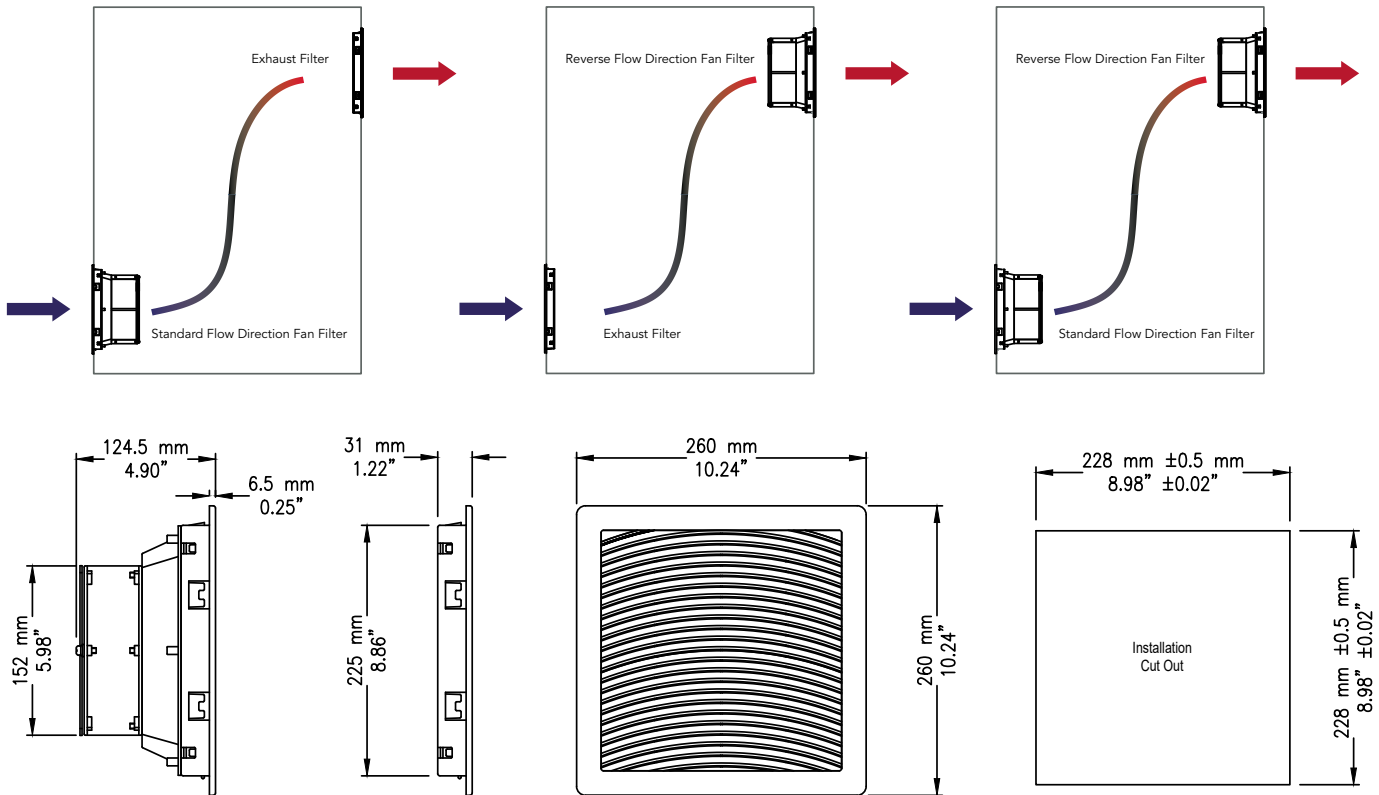

FTEC26L4X-115SBB/FTEC26L4X-230SBB

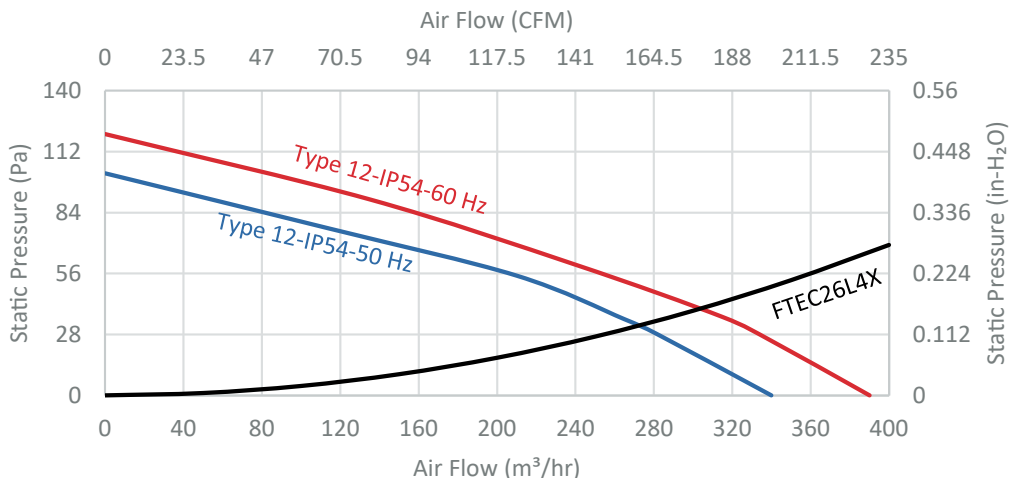

FTEC26L5()-115SBB/FTEC26L5(**)-230SBB**

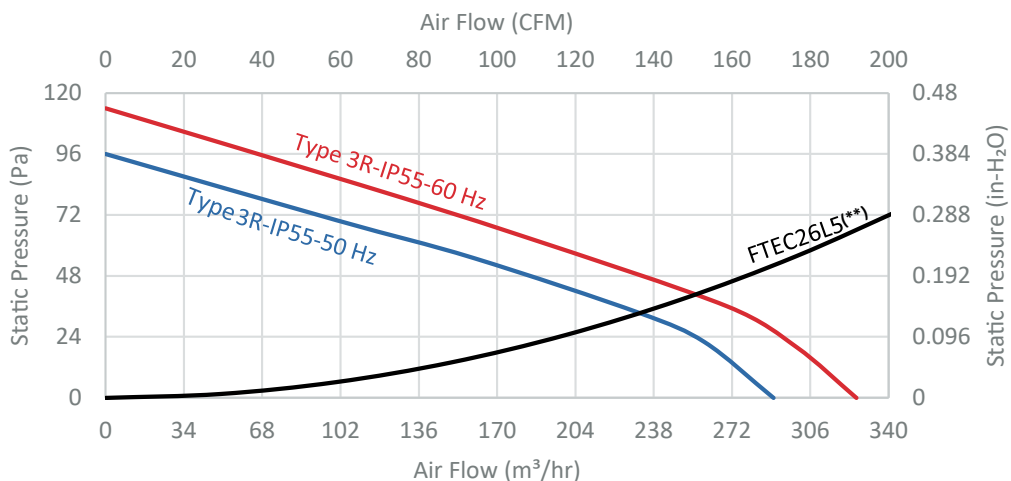

FTEC26L4X-48DSB/FTEC26L5()-48DSB**

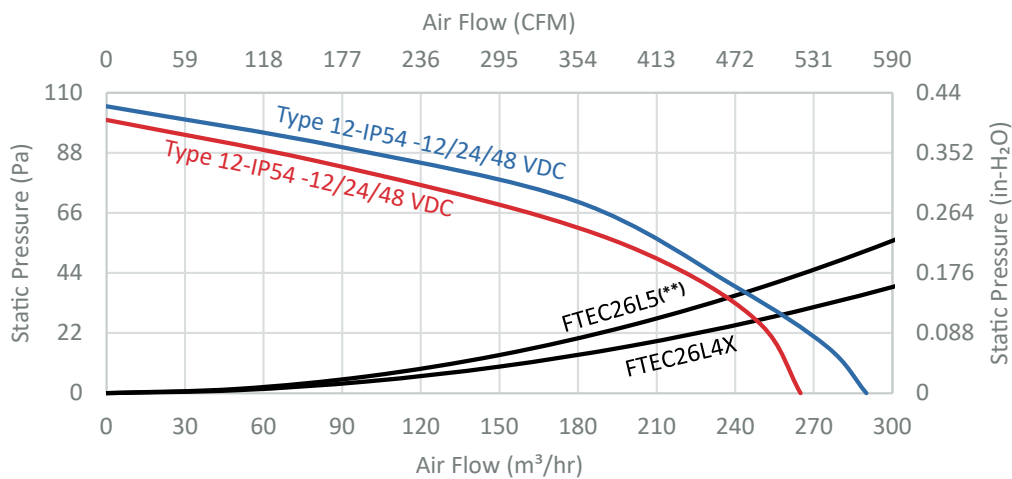

FTEC 32 SERIES

FTEC32 series Performance Chart - 12" Fan Filter and Exhaust Filter

NEMA Rating	Type 12			Type 12 or Type 3R		
	IP 54			IP 55		
Filter Media	G3					
Rated Voltage	100-120 VAC	200-240 VAC	12/24/48 VDC	100-120 VAC	200-240 VAC	12/24/48 VDC
Frequency	60/50 Hz	60/50 Hz		60/50 Hz	60/50 Hz	
Bearing	Two Ball Bearing	Two Ball Bearing	Two Ball Bearing	Two Ball Bearing	Two Ball Bearing	Two Ball Bearing
Power connection	3 Poles screwless connector or 2 Pin terminal			3 Poles screwless connector or 2 Pin terminal		
Fan Filters						
RAL 7035 Light Gray	FTEC32L4X-115SB	FTEC32L4X-230SB	FTEC32L4X-(-)DSB	FTEC32L5(**)-115SB	FTEC32L5(**)-230SB	FTEC32L5(**)-(-)DSB
RAL 7032 Dark Gray	FTEC32D4X-115SB	FTEC32D4X-230SB	FTEC32D4X-(-)DSB	FTEC32D5(**)-115SB	FTEC32D5(**)-230SB	FTEC32D5(**)-(-)DSB
RAL 9011 Black	FTEC32B4X-115SB	FTEC32B4X-230SB	FTEC32B4X-(-)DSB	FTEC32B5(**)-115SB	FTEC32B5(**)-230SB	FTEC32B5(**)-(-)DSB
Reverse Flow Fan Filter	FTEC32L4X-115RBB	FTEC32L4X-230RBB	FTEC32L4X-(-)DRB	FTEC32L5(**)-115RBB	FTEC32L5(**)-230RBB	FTEC32L5(**)-(-)DRB
Flow Capacity (CFM-m³/hr at 60/50 Hz) and Maximum Static Pressure (in H₂O-Pa at 60/50 Hz)						
Unimpeded (***)	380/360 CFM-645/610 m ³ /hr	380/360 CFM-645/610 m ³ /hr	550 CFM-935 m ³ /hr	350/335 CFM-595/570 m ³ /hr	350/335 CFM-595/570 m ³ /hr	500 CFM-850 m ³ /hr
In combination						
Fan Filter+Exhaust Filter	220/210 CFM-375/355 m ³ /hr	220/210 CFM-375/355 m ³ /hr	330 CFM-560 m ³ /hr	190/180 CFM-320/305 m ³ /hr	190/180 CFM-320/305 m ³ /hr	280 CFM-475 m ³ /hr
Max. Static Pressure	0.44/0.40-110/100	0.44/0.40-110/100	0.60/150	0.42/0.40-105/100	0.42/0.40-105/100	0.54-135
Fan Filter+Reverse Flow Fan Filter	320/300 CFM-545/510 m ³ /hr	320/300 CFM-545/510 m ³ /hr	450 CFM-765 m ³ /hr	270/255 CFM-460/435 m ³ /hr	270/255 CFM-460/435 m ³ /hr	400 CFM-680 m ³ /hr
Max. Static Pressure	0.50/0.48-125/120	0.50/0.48-125/120	0.72-180	0.47/0.44-118/110	0.47/0.44-118/110	0.62-155
Other Fan Filters Data						
Power Input	35/23 W	35/23 W	64.8/63.6/62.4 W	35/23 W	35/23 W	64.8/63.6/62.4 W
Weight	3700 gram / 8.15 lb		3700 gram / 8.15 lb	3700 gram / 8.15 lb		3700 gram / 8.15 lb
Noise Level	48/50 dB (A)		60 dB (A)	47/49 dB (A)		60 dB (A)
Durability	80,000 @ 35 °C	80,000 @ 35 °C	90,000 @ 35 °C	80,000 @ 35 °C	80,000 @ 35 °C	90,000 @ 35 °C
Operating Temperature	-20 to +70 °C / -4 to +158 °F			-20 to +70 °C / -4 to +158 °F		
Dimensions	12.84" X 12.84" X 6.38" / 326 X 326 X 162 mm ³			12.84" X 12.84" X 6.38" / 326 X 326 X 162 mm ³		
Certificates	CSA-UL-CE			CSA-UL-CE		
Exhaust Filter						
	Type 12-IP 54			Type 12 or Type 3R-IP55		
RAL 7035 Light Gray	FTEC32L4X			FTEC32L5(**)		
RAL 7032 Dark Gray	FTEC32D4X			FTEC32D5(**)		
RAL 9011 Black	FTEC32B4X			FTEC32B5(**)		
Dimensions	12.84" X 12.84" X 1.22" / 326 X 326 X 31 mm ³			12.84" X 12.84" X 1.22" / 326 X 326 X 31 mm ³		
Weight	750/1.65			750/1.65		
Certificates	CSA-UL-CE			CSA-UL-CE		
Accessories						
Replacement Filter Media	FTEC32-FM-4			FTEC32-FM-5		
NO Thermostat (°C)	TTEC-200-C/EETEC-400		EETEC-400	TTEC-200-C/EETEC-400		EETEC-400
NO Thermostat (°F)	TTEC-200-F/EETEC-400		EETEC-400	TTEC-200-F/EETEC-400		EETEC-400

(*) 12 means 12 VDC, 24 means 24 VDC, and 48 means 48 VDC

(**) Flow capacity at 90 VAC - 60 Hz (Type 12) is 295 CFM

(**) X represents Type 12, IP 54 or IP 55, Z represents Type 3R IP 55

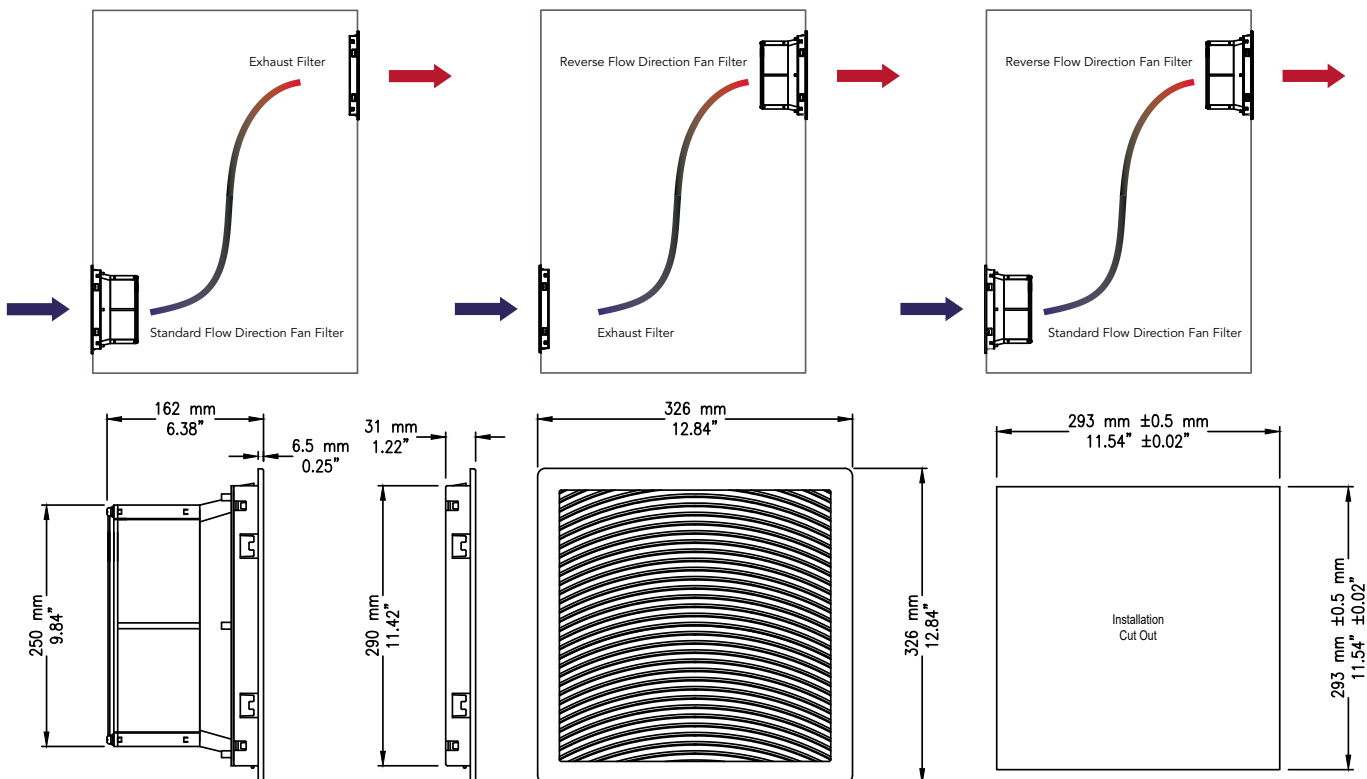

FTEC32L4X-115SB/FTEC32L4X-230SB

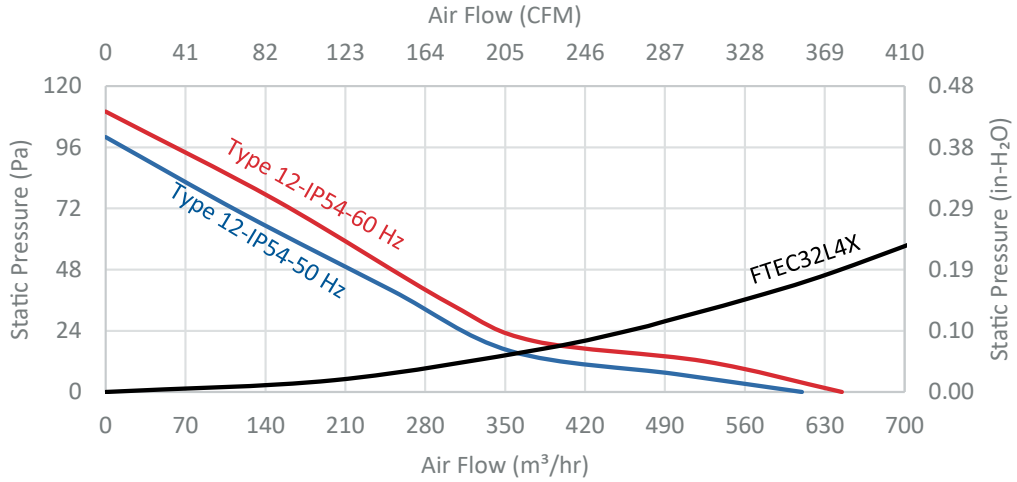

FTEC32L5()-115SB/FTEC32L5(**)-230SB**

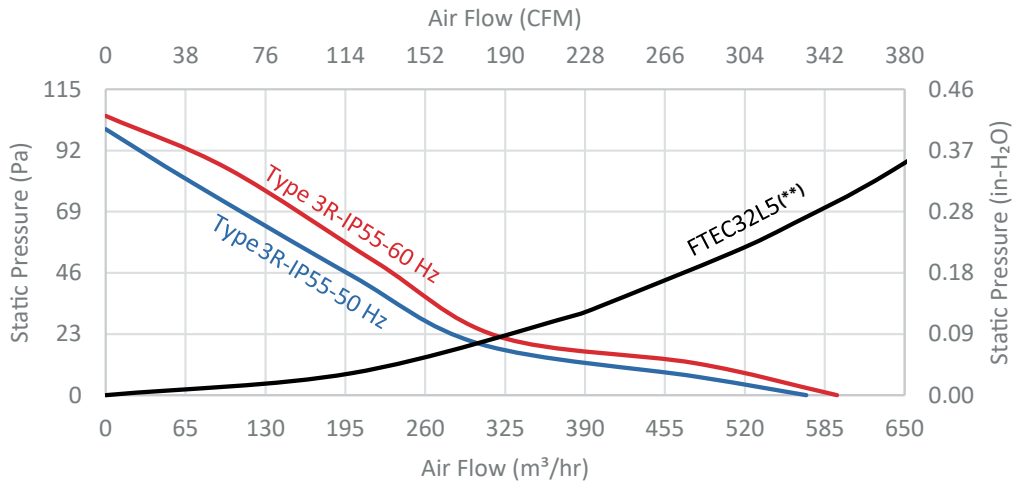

FTEC32L4X-48DSB/FTEC32L5()-48DSB**

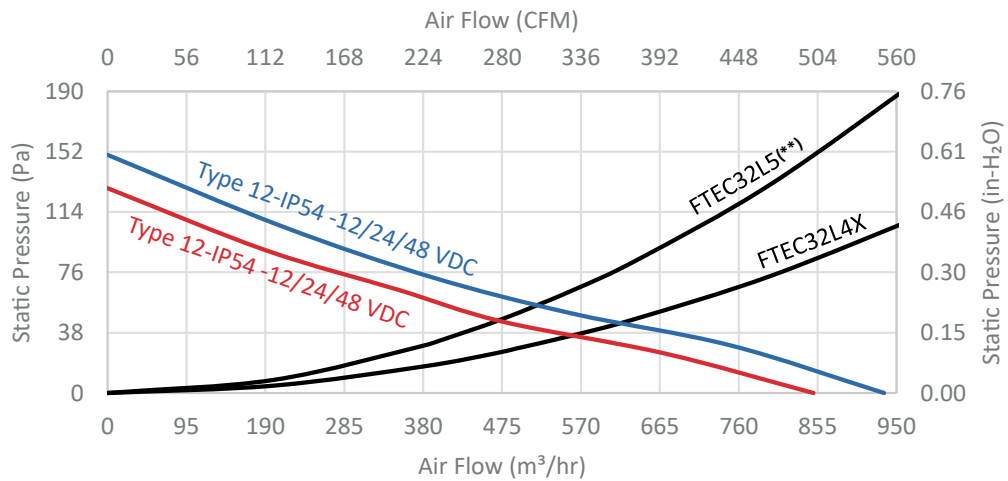

FTEC 32B SERIES

FTEC32B series Performance Chart - 12" Fan Filter and Exhaust Filter

NEMA Rating	Type 12			Type 12 or Type 3R		
	IP 54			IP 55		
Filter Media	G3			G4		
Rated Voltage	100-120 VAC	200-240 VAC	12/24/48 VDC	100-120 VAC	200-240 VAC	12/24/48 VDC
Frequency	60/50 Hz	60/50 Hz		60/50 Hz	60/50 Hz	
Bearing	Two Ball Bearing	Two Ball Bearing	Two Ball Bearing	Two Ball Bearing	Two Ball Bearing	Two Ball Bearing
Power connection	3 Poles screwless connector or 2 Pin terminal			3 Poles screwless connector or 2 Pin terminal		
Fan Filters						
RAL 7035 Light Gray	FTEC32L4X-115SBB	FTEC32L4X-230SBB	FTEC32L4X-(-)DSB	FTEC32L5(**)-115SBB	FTEC32L5(**)-230SBB	FTEC32L5(**)-(-)DSB
RAL 7032 Dark Gray	FTEC32D4X-115SBB	FTEC32D4X-230SBB	FTEC32D4X-(-)DSB	FTEC32D5(**)-115SBB	FTEC32D5(**)-230SBB	FTEC32D5(**)-(-)DSB
RAL 9011 Black	FTEC32B4X-115SBB	FTEC32B4X-230SBB	FTEC32B4X-(-)DSB	FTEC32B5(**)-115SBB	FTEC32B5(**)-230SBB	FTEC32B5(**)-(-)DSB
Reverse Flow Fan Filter	FTEC32L4X-115RBB	FTEC32L4X-230RBB	FTEC32L4X-(-)DRB	FTEC32L5(**)-115RBB	FTEC32L5(**)-230RBB	FTEC32L5(**)-(-)DRB
Flow Capacity (CFM-m³/hr at 60/50 Hz) and Maximum Static Pressure (in H₂O-Pa at 60/50 Hz)						
Unimpeded (***)	450/425 CFM-765/722 m ³ /hr	450/425 CFM-765/722 m ³ /hr	550 CFM - 935 m ³ /hr	418/396 CFM-712/675 m ³ /hr	418/396 CFM-712/675 m ³ /hr	500 CFM - 850 m ³ /hr
In combination						
Fan Filter+Exhaust Filter	290/275 CFM-492/467 m ³ /hr	290/275 CFM-492/467 m ³ /hr	330 CFM - 560 m ³ /hr	235/225 CFM-400/380 m ³ /hr	235/225 CFM-400/380 m ³ /hr	280 CFM - 475 m ³ /hr
Max. Static Pressure	0.50/0.46 -125/115	0.50/0.46 -125/115	0.60/150	0.48/0.44 -120/110	0.48/0.44 -120/110	0.54 -135
Fan Filter+Reverse Flow Fan Filter	425/400 CFM-722/680 m ³ /hr	425/400 CFM-722/680 m ³ /hr	450 CFM - 765 m ³ /hr	385/365 CFM - 655/622 m ³ /hr	385/365 CFM - 655/622 m ³ /hr	400 CFM - 680 m ³ /hr
Max. Static Pressure	0.56/0.51-140/128	0.56/0.51-140/128	0.72 -180	0.53/0.50-132/125	0.53/0.50-132/125	0.62 -155
Other Fan Filters Data						
Power Input	75/60 W	75/60 W	64.8/63.6/62.4 W	75/60 W	75/60 W	64.8/63.6/62.4 W
Weight	3700 gram / 8.15 lb		3700 gram / 8.15 lb	3700 gram / 8.15 lb		3700 gram / 8.15 lb
Noise Level	58/61 dB (A)		60 dB (A)	56/59 dB (A)		60 dB (A)
Durability	80,000 @ 35 °C	80,000 @ 35 °C	90,000 @ 35 °C	80,000 @ 35 °C	80,000 @ 35 °C	90,000 @ 35 °C
Operating Temperature	-20 to +70 °C / -4 to +158 °F			-20 to +70 °C / -4 to +158 °F		
Dimensions	12.84" X 12.84" X 6.38" / 326 X 326 X 162 mm ³			12.84" X 12.84" X 6.38" / 326 X 326 X 162 mm ³		
Certificates	CSA-UL-CE			CSA-UL-CE		
Exhaust Filter						
	Type 12-IP 54			Type 12 or Type 3R-IP55		
RAL 7035 Light Gray	FTEC32L4X			FTEC32L5(**)		
RAL 7032 Dark Gray	FTEC32D4X			FTEC32D5(**)		
RAL 9011 Black	FTEC32B4X			FTEC32B5(**)		
Dimensions	12.84" X 12.84" X 1.22" / 326 X 326 X 31 mm ³			12.84" X 12.84" X 1.22" / 326 X 326 X 31 mm ³		
Weight	750 gram / 1.65 lb			750 gram / 1.65 lb		
Certificates	CSA-UL-CE			CSA-UL-CE		
Accessories						
Replacement Filter Media	FTEC32-FM-4			FTEC32-FM-5		
NO Thermostat (°C)	TTEC-200-C / ETEC-400		ETEC-400	TTEC-200-C / ETEC-400		ETEC-400
NO Thermostat (°F)	TTEC-200-F / ETEC-400		ETEC-400	TTEC-200-F / ETEC-400		ETEC-400

(*) 12 means 12 VDC, 24 means 24 VDC, and 48 means 48 VDC

(***) Flow capacity at 90 VAC -60 Hz (Type 12) is 350 CFM

(**) X represents Type 12, IP 54 or IP 55, Z represents Type 3R IP 55

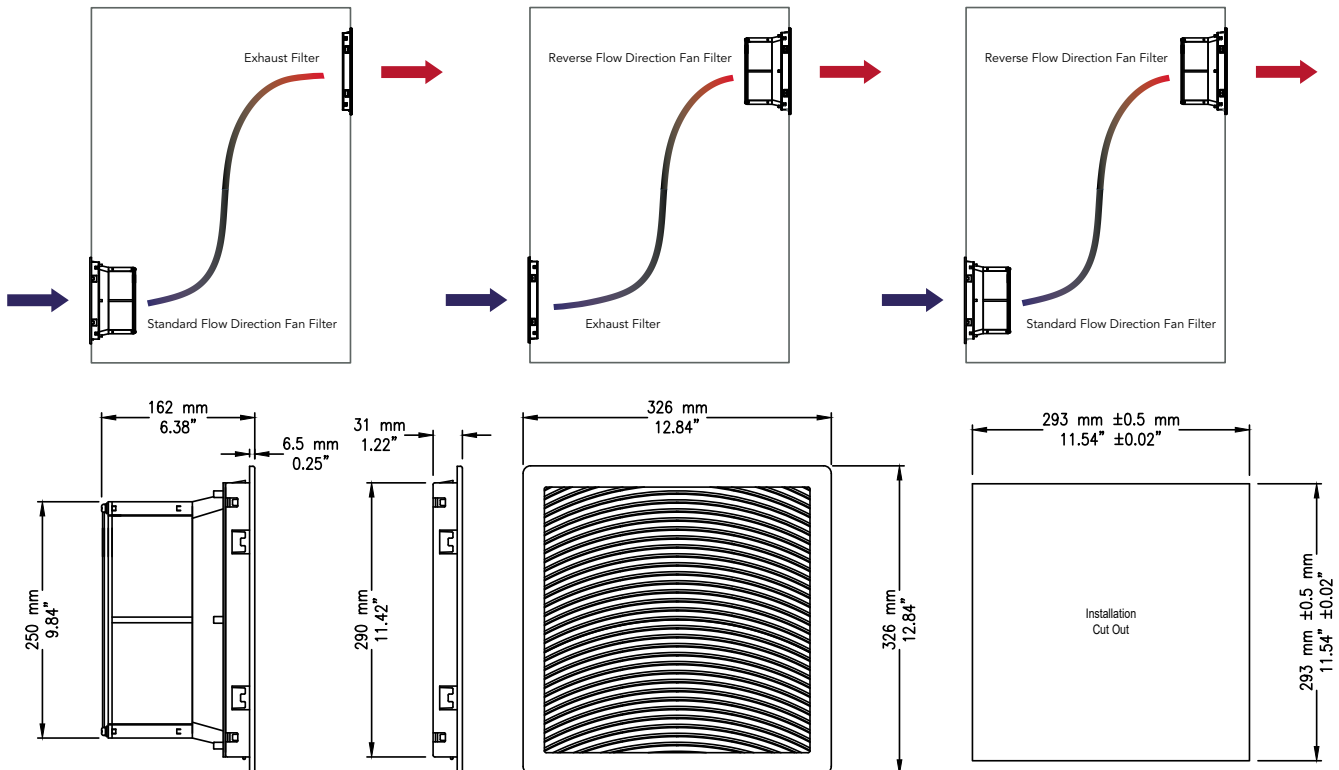

FTEC32L4X-115SBB/FTEC32L4X-230SBB

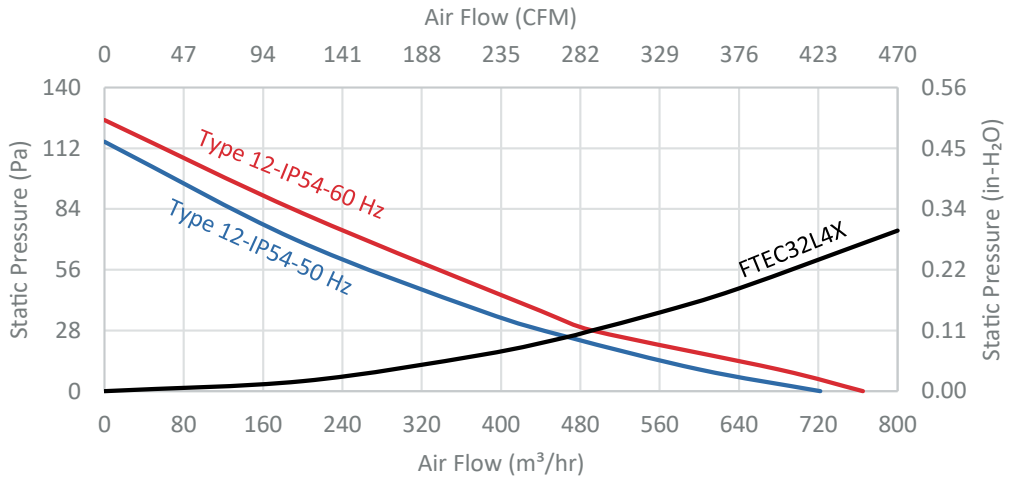

FTEC32L5()-115SBB/FTEC32L5(**)-230SBB**

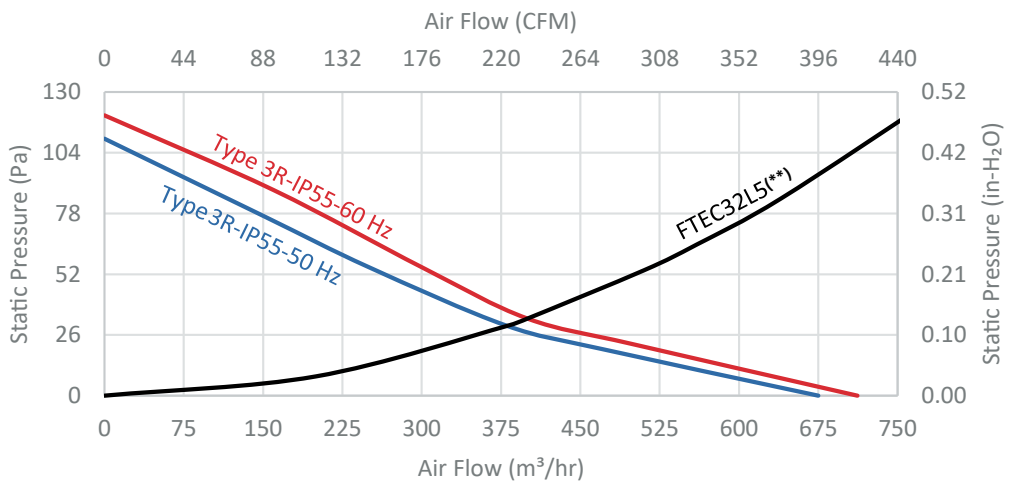

FTEC32L4X-48DSB/FTEC32L5()-48DSB**

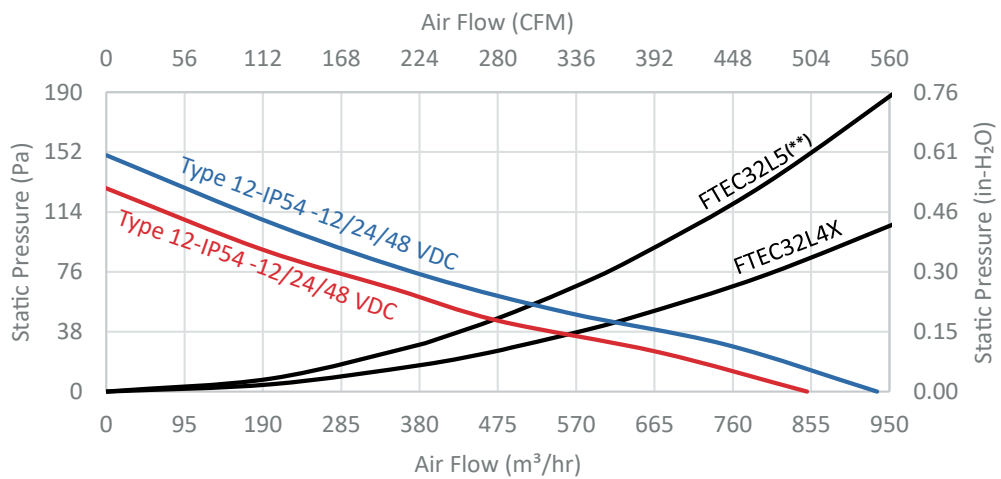

FTEC 32G SERIES

FTEC32G series Performance Chart - 12" Fan Filter and Exhaust Filter

NEMA Rating	Type 12			Type 12 or Type 3R		
IP Rating	IP 54			IP 55		
Filter Media	G3			G4		
Rated Voltage	100-120 VAC	200-240/440-480 VAC	12/24/48 VDC	100-120 VAC	200-240/440-480 VAC	12/24/48 VDC
Frequency	60/50 Hz	60/50 Hz		60/50 Hz	60/50 Hz	
Bearing	Two Ball Bearing	Two Ball Bearing	Two Ball Bearing	Two Ball Bearing	Two Ball Bearing	Two Ball Bearing
Power connection	3 Poles screwless connector or 2 Pin terminal			3 Poles screwless connector or 2 Pin terminal		
Fan Filters						
RAL 7035 Light Gray	FTEC32L4X-115SBG	FTEC32L4X-(***)SBG	FTEC32L4X-(*)DSB	FTEC32L5(**)-115SBG	FTEC32L5(**)-230SBG	FTEC32L5(**)-(*)DSB
RAL 7032 Dark Gray	FTEC32D4X-115SBG	FTEC32D4X-(***)SBG	FTEC32D4X-(*)DSB	FTEC32D5(**)-115SBG	FTEC32D5(**)-230SBG	FTEC32D5(**)-(*)DSB
RAL 9011 Black	FTEC32B4X-115SBG	FTEC32B4X-(***)SBG	FTEC32B4X-(*)DSB	FTEC32B5(**)-115SBG	FTEC32B5(**)-230SBG	FTEC32B5(**)-(*)DSB
Reverse Flow Fan Filter	FTEC32L4X-115RBG	FTEC32L4X-(***)RBG	FTEC32L4X-(*)DRB	FTEC32L5(**)-115RBG	FTEC32L5(**)-(***)RBG	FTEC32L5(**)-(*)DRB
Flow Capacity (CFM-m³/hr at 60/50 Hz) and Maximum Static Pressure (in H₂O-Pa at 60/50 Hz)						
Unimpeded (***)	625/595 CFM-1060/1010 m ³ /hr	625/595 CFM-1060/1010 m ³ /hr	550 CFM-935 m ³ /hr	595/565 CFM-1010/960 m ³ /hr	595/565 CFM-1010/960 m ³ /hr	500 CFM-850 m ³ /hr
In combination						
Fan Filter+Exhaust Filter	430/410 CFM-730/695 m ³ /hr	430/410 CFM-730/695 m ³ /hr	330 CFM-560 m ³ /hr	420/400 CFM-715/680 m ³ /hr	420/400 CFM-715/680 m ³ /hr	280 CFM-475 m ³ /hr
Max. Static Pressure	0.82/0.77-205/192	0.82/0.77-205/192	0.60/150	0.80/0.76-198/188	0.80/0.76-198/188	0.54 - 135
Fan Filter+Reverse Flow Fan Filter	570/540 CFM-968/917 m ³ /hr	570/540 CFM-968/917 m ³ /hr	450 CFM-765 m ³ /hr	530/510 CFM-900/866 m ³ /hr	530/510 CFM-900/866 m ³ /hr	400 CFM-680 m ³ /hr
Max. Static Pressure	0.88/0.84-220/210	0.56/0.51-140/128	0.72 - 180	0.84/0.81-210/202	0.84/0.81-210/202	0.62 - 155
Other Fan Filters Data						
Power Input	105/95 W	105/95 W	64.8/63.6/62.4 W	105/95 W	105/95 W	64.8/63.6/62.4 W
Weight	3,700 gram /8.16 lb		3,700 gram /8.16 lb	3,700 gram /8.16 lb		3,700 gram /8.16 lb
Noise Level	68/70 dB (A)		60 dB (A)	68/70 dB (A)		60 dB (A)
Durability	50,000 @ 55 °C	50,000 @ 55 °C	90,000 @ 35 °C	50,000 @ 55 °C	50,000 @ 55 °C	90,000 @ 35 °C
Operating Temperature	-20 to +70 gram /-4 to +158 lb			-20 to +70 gram /-4 to +158 lb		
Dimensions	12.84" X 12.84" X 6.38" / 326 X 326 X 162 mm ³			12.84" X 12.84" X 6.38" / 326 X 326 X 162 mm ³		
Certificates	CSA and UL Pending-CE			CSA and UL Pending-CE		
Exhaust Filter						
	Type 12-IP 54			Type 12 or Type 3R-IP55		
RAL 7035 Light Gray	FTEC32L4X			FTEC32L5(**)		
RAL 7032 Dark Gray	FTEC32D4X			FTEC32D5(**)		
RAL 9011 Black	FTEC32B4X			FTEC32B5(**)		
Dimensions	12.84" X 12.84" X 1.22" / 326 X 326 X 31 mm ³			12.84" X 12.84" X 1.22" / 326 X 326 X 31 mm ³		
Weight	750/1.65			750/1.65		
Certificates	CSA-UL-CE			CSA-UL-CE		
Accessories						
Replacement Filter Media	FTEC32-FM-4			FTEC32-FM-5		
NO Thermostat (°C)	TTEC-200-C / ETEC-400		ETEC-400	TTEC-200-C / ETEC-400		ETEC-400
NO Thermostat (°F)	TTEC-200-F / ETEC-400		ETEC-400	TTEC-200-F / ETEC-400		ETEC-400

(*) 12 means 12 VDC, 24 means 24 VDC, and 48 means 48 VDC

(**) 230 represents 230 VAC, and 440 VAC represents 460VAC

(**) X represents Type 12, IP 54 or IP 55 and Z represents Type 3R, IP 55

(****) Flow capacity at 90 VAC - 60 Hz (Type 12) is 520 CFM

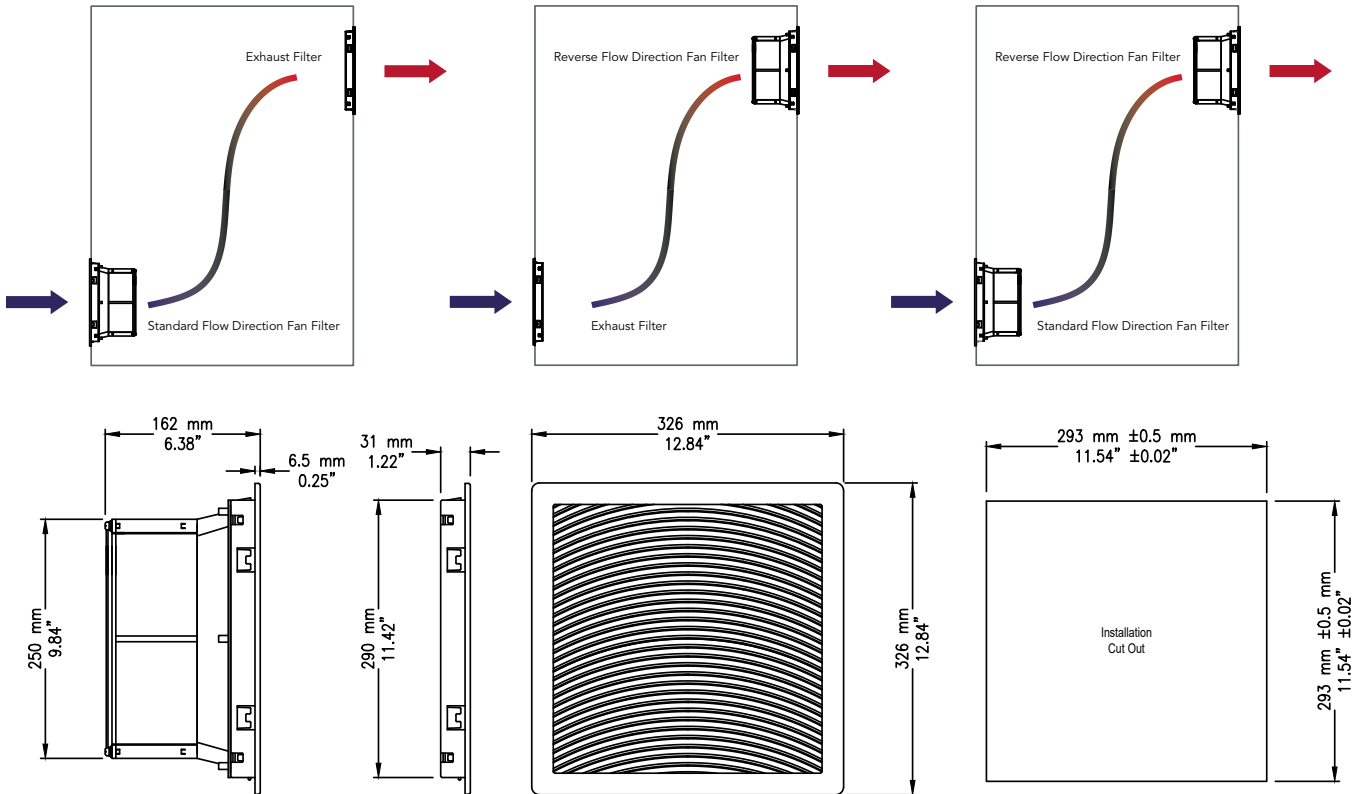

FTEC32L4X-115SBG/FTEC32L4X-230SBG/FTEC32L4X-440SBG

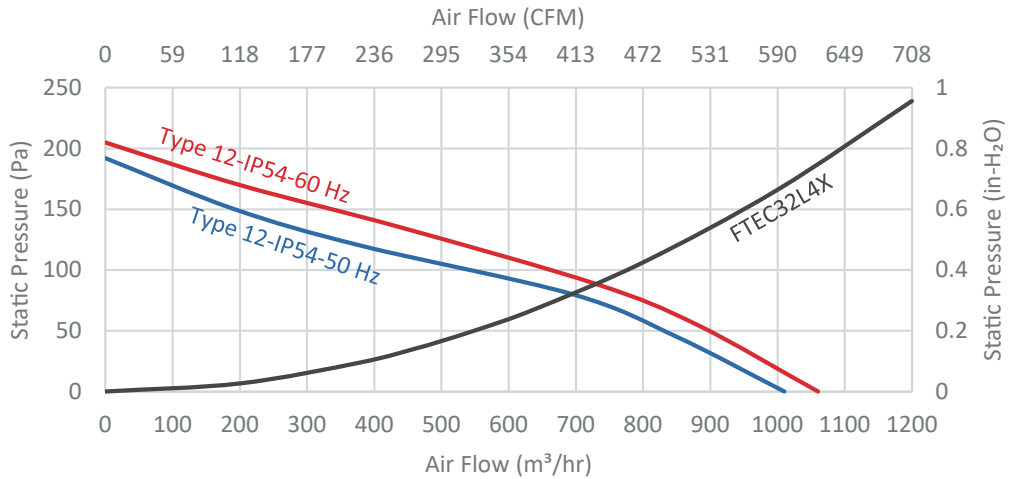

FTEC32L5()-115SBG/FTEC32L5(**)-230SBG-FTEC32L5(**)-440SBG**

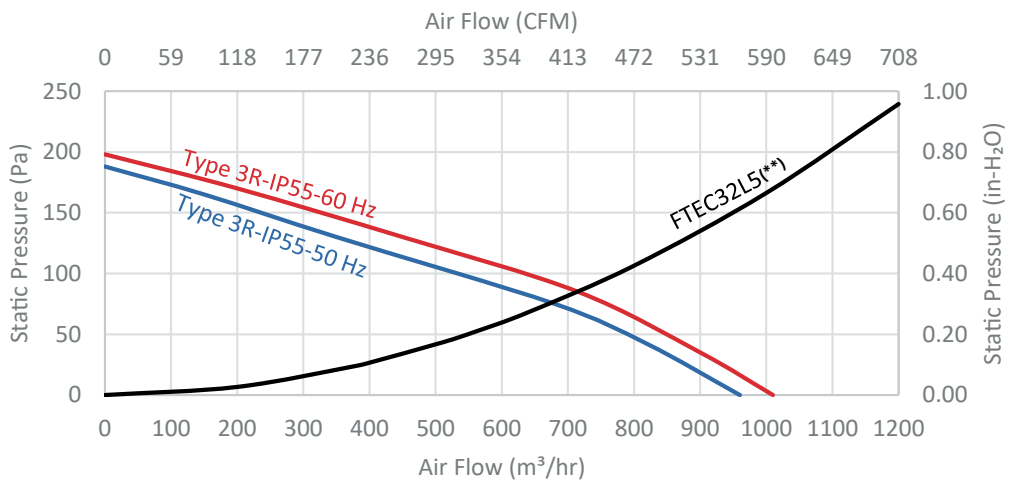

FTEC32L4X-48DSB/FTEC32L5()-48DSB**

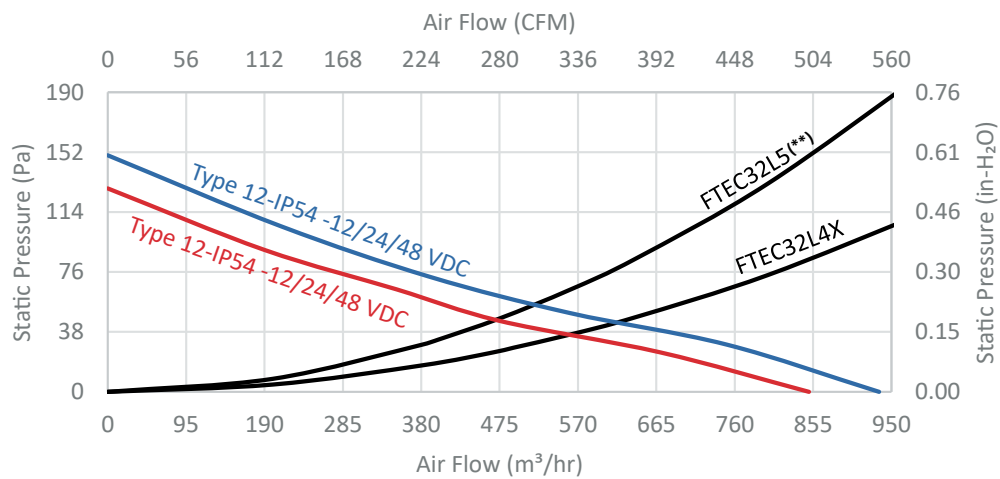

AXIAL FAN

FANTEC Series

FANTEC

Certificates

- UL and cUL Recognized, File Number E508880
- CE Compliant

Application

FANTEC series Axial Fans are designed to supply forced convection air to enclosures and electrical panels. By using the unique cooling features, FANTECs will cool down the inside of enclosures to a desired temperature to protect the electrical and electronic parts against heat.

Features

- Wide range of operating temperatures from -40 °C/-40 °F to 70 °C/158 °F
- Fans are available in 24, 115, 230 VAC, 460 VAC and 12, 24, and 48 VDC
- Airflow from 24 CFM to 1300 CFM (40 m3/hr to 2200 m3/hr)
- Thermally, Electronically or Impedance Protected
- From 50,000 to 90,000 life cycle
- Aluminum Die Cast or UL94-V0 thermoplastic housing
- AC/DC fans are available with Dry Contact relay

Color

- Black / Grey



Model No.	Outline Dimension	Rated Voltage	Power Consumption	Rotating Speed	Max. Air Flow	Max. Static Pressure	Noise Level	Durability
AC Centrifugal Fans, backward curved blades - 115 V and 230 V								
ARC225C115XBTP	225 mm X 99 mm	100-120 VAC 50/60 Hz	40/45 W	1450/1750 RPM	595/678 m ³ /hr	13.97/19.81 mmH ₂ O	53/55 db(A)	70,000 at 25 °C
	8.8" X 3.9"				350/400 CFM	0.55/0.78 inchH ₂ O		
ARC225C230XBTP	225 mm X 99 mm	200-240 VAC 50/60 Hz	40/45 W	1450/1750 RPM	595/678 m ³ /hr	13.97/19.81 mmH ₂ O	53/55 db(A)	70,000 at 25 °C
	8.8" X 3.9"				350/400 CFM	0.55/0.78 inchH ₂ O		
ARC225S115XBTP	225 mm X 99 mm	100-120 VAC 50/60 Hz	109/145 W	2500/2600 RPM	1086/1086 m ³ /hr	50.8/63.5 mmH ₂ O	70/73 db(A)	70,000 at 25 °C
	8.8" X 3.9"				640/640 CFM	2.0/2.5 inchH ₂ O		
ARC225S230XBTP	225 mm X 99 mm	200-240 VAC 50/60 Hz	109/145 W	2500/2600 RPM	1086/1086 m ³ /hr	50.8/63.5 mmH ₂ O	70/73 db(A)	70,000 at 25 °C
	8.8" X 3.9"				640/640 CFM	2.0/2.5 inchH ₂ O		
AC-DC Energy Saving EC Fans								
ARE17251115XBTP	172 mm X 150 mm X 51 mm	100-120 V	26/35 W ± 10%	5000 RPM ± 10%	612 m ³ /hr	41.15 mmH ₂ O	68 db(A)	70,000 hrs @ 40 °C
	6-49/64" X 5-29/32" X 2-1/64"				360 CFM	1.62 inchH ₂ O		
ARE17251230XBTP	172 mm X 150 mm X 51 mm	200-240 V	26/35 W ± 10%	5000 RPM ± 10%	612 m ³ /hr	41.15 mmH ₂ O	68 db(A)	70,000 hrs @ 40 °C
	6-49/64" X 5-29/32" X 2-1/64"				360 CFM	1.62 inchH ₂ O		
DC Brushless Fans - 12 V								
AR802512XBTP	80 mm X 80 mm X 38 mm	8-13.8 VDC	2.2 W	3300 RPM ± 10%	66 m ³ /hr	5.84 mmH ₂ O	33 db(A)	60,000 hrs @ 45 °C
	3-5/32" X 3-5/32" X 1"				40 CFM	0.23 inchH ₂ O		
AR1203812XBTP	120 mm X 120 mm X 38 mm	8-13.8 VDC	10.6 (Max. 17) W	4200 RPM ± 10%	306 m ³ /hr	24.89 mmH ₂ O	54 db(A)	65,000 hrs @ 45 °C
	4-23/32" X 4-23/32" X 1-1/2"				180 CFM	0.988 inchH ₂ O		
AR1725112XBTP	172 mm X 150 mm X 51 mm	8-13.8 VDC	23 W ± 10%	4000 RPM ± 10%	534 m ³ /hr	23.11 mmH ₂ O	61.5 db(A)	90,000 hrs @ 35 °C
	6-49/64" X 5-29/32" X 2-1/64"				315 CFM	0.91 inchH ₂ O		
AR25489512XBTP	254 X 89 mm	9-13 VDC	64.8 W ± 10%	2400 RPM ± 10%	1,410 m ³ /hr	19.81 mmH ₂ O	60 db(A)	90,000 hrs @ 35 °C
	10" X 3-1/2"				830 CFM	0.78 inchH ₂ O		
DC Brushless Fans - 24 V								
AR802524XBTP	80 mm X 80 mm X 38 mm	12-27.6 VDC	2.9 W	3300 RPM ± 10%	66 m ³ /hr	5.84 mmH ₂ O	33 db(A)	60,000 hrs @ 45 °C
	3-5/32" X 3-5/32" X 1"				40 CFM	0.23 inchH ₂ O		
AR1203824XBTP	120 mm X 120 mm X 38 mm	15-26VDC	10.3 (Max. 22) W	4200 RPM ± 10%	306 m ³ /hr	24.89 mmH ₂ O	55 db(A)	65,000 hrs @ 45 °C
	4-23/32" X 4-23/32" X 1-1/2"				180 CFM	0.988 inchH ₂ O		
AR1725124XBTP	172 mm X 150 mm X 51 mm	15-27.6 VDC	24W ± 10%	4000 RPM ± 10%	534 m ³ /hr	23.11 mmH ₂ O	61.5 db(A)	90,000 hrs @ 35 °C
	6-49/64" X 5-29/32" X 2-1/64"				315 CFM	0.91 inchH ₂ O		
AR25489524XBTP	254 X 89 mm	16-27 VDC	63.6 W ± 10%	2500 RPM ± 10%	1,446 m ³ /hr	21.08 mmH ₂ O	62 db(A)	90,000 hrs @ 35 °C
	10" X 3-1/2"				850 CFM	0.83 inchH ₂ O		
DC Brushless Fans - 24 V - (with output relay)								
AR1203824XBTP (R4)	120 mm X 120 mm X 38 mm	15-26VDC	8.4 (Max. 14.8) W	3200 RPM ± 10%	234 m ³ /hr	14.22 mmH ₂ O	48 db(A)	65,000 hrs @ 45 °C
	4-23/32" X 4-23/32" X 1-1/2"				136 CFM	0.56 inchH ₂ O		
DC Brushless Fans - 48 V								
AR802548XBTP	80 mm X 80 mm X 38 mm	24-56 VDC	3.8 W	3300 RPM ± 10%	66 m ³ /hr	5.84 mmH ₂ O	33 db(A)	60,000 hrs @ 45 °C
	3-5/32" X 3-5/32" X 1"				40 CFM	0.23 inchH ₂ O		
AR1203848XBTP	120 mm X 120 mm X 38 mm	28-55 VDC	10.6 (Max. 20) W	4200 RPM ± 10%	306 m ³ /hr	24.89 mmH ₂ O	56 db(A)	65,000 hrs @ 45 °C
	4-23/32" X 4-23/32" X 1-1/2"				180 CFM	0.988 inchH ₂ O		
AR1725148XBTP	172 mm X 150 mm X 51 mm	22-56 VDC	23.5 W ± 10%	4000 RPM ± 10%	534 m ³ /hr	23.11 mmH ₂ O	61.5 db(A)	90,000 hrs @ 35 °C
	6-49/64" X 5-29/32" X 2-1/64"				315 CFM	0.91 inchH ₂ O		
AR25489548XBTP	254 X 89 mm	24-53 VDC	62.4 W ± 10%	2500 RPM ± 10%	1,218.6 m ³ /hr	21.08 mmH ₂ O	62 db(A)	90,000 hrs @ 35 °C
	10" X 3-1/2"				718 CFM	0.83 inchH ₂ O		

Axial Fan product codes ending with P or () are for plastic impellers, product codes ending with M are for metal impellers

UL
E508880



TECHNICAL DATA

Model No.	Outline Dimension	Rated Voltage	Power Consumption	Rotating Speed	Max. Air Flow	Max. Static Pressure	Noise Level	Durability
AC Axial Fans - 115 V								
AR8038115XBT	80 mm X 80 mm X 38 mm	100-120 VAC 50/60 Hz	12/9 W ± 10%	2400/2900 RPM ± 10%	41/48 m³/hr	3.5/4.9 mmH2O	33/38 db(A)	50,000 hrs @ 25 °C
	3-5/32" X 3-5/32" X 1-1/2"				24/28.4 CFM	0.14/0.19 inchH2O		
AR8038115XBTP	80 mm X 80 mm X 38 mm	100-120 VAC 50/60 Hz	14/12 W ± 10%	2700/3250 RPM ± 10%	42/54 m³/hr	4.06/5.59 mmH2O	29 db(A)	80,000 hrs @ 45 °C
	3-5/32" X 3-5/32" X 1-1/2"				26/31 CFM	0.16/0.22 inchH2O		
AR12038115XBT	120 mm x 120 mm x 38 mm	100-120 VAC 50/60 Hz	20/17 W ± 10%	2650/3000 RPM ± 10%	143/163 m³/hr	7.5/7.8 mmH2O	43/47 db(A)	50,000 hrs @ 25 °C
	4-23/32" X 4-23/32" X 1-1/2"				84/96 CFM	0.30/0.31 inchH2O		
AR12038115XBTP	120 mm x 120 mm x 38 mm	100-120 VAC 50/60 Hz	16/14 W ± 10%	2600/3050 RPM ± 10%	180/210 m³/hr	7.62/8.13 mmH2O	45 db(A)	80,000 hrs @ 45 °C
	4-23/32" X 4-23/32" X 1-1/2"				106/125 CFM	0.30/0.32 inchH2O		
AR17251115XBT	172 mm X 150 mm X 51 mm	100-120 VAC 50/60 Hz	43/40 W ± 10%	2700/3000 RPM ± 10%	298/306 m³/hr	12/7.5 mmH2O	56/58 db(A)	50,000 hrs @ 25 °C
	6-49/64" X 5-29/32" X 2-1/64"				175/180 CFM	0.47/0.30 inchH2O		
AR17251115XBTM	172 mm X 150 mm X 51 mm	100-120 VAC 50/60 Hz	26/35 W ± 10%	2750/3150 RPM ± 10%	354/426 m³/min	13.97/14.73 mmH2O	58 db(A)	50,000 hrs @ 55 °C
	6-49/64" X 5-29/32" X 2-1/64"				210/250 CFM	0.55/0.58 inchH2O		
AR225G115XBTM	225 mm X 240 mm X 80 mm	100-120 VAC 50/60 Hz	60/80 W ± 10%	2700/3100 RPM ± 10%	918/1,056 m³/min	20.32/18.8 mmH2O	66 db(A)	45,000 hrs @ 55 °C
	8.9" X 9.5" X 3.1"				540/620 CFM	0.8/0.74 inchH2O		
AR25089C115XBTP	ø 254 X 89 mm	100-120 VAC 50/60 Hz	23/35 W ± 10%	1450/1680 RPM ± 10%	780/930 m³/hr	10.92/11.94 mmH2O	45 db(A)	80,000 hrs @ 35 °C
	ø 10" X 3-1/2"				460/550 CFM	0.43/0.47 inchH2O		
AR25089S115XBTP	ø 254 X 89 mm	100-120 VAC 50/60 Hz	60/75 W ± 10%	2600/2700 RPM ± 10%	1,392/1,464 m³/hr	19.81/18.54 mmH2O	65 db(A)	80,000 hrs @ 35 °C
	ø 10" X 3-1/2"				820/860 CFM	0.78/0.73 inchH2O		
AR25089G115XBTM	ø 254 X 89 mm	100-120 VAC 50/60 Hz	95/105 W ± 10%	2800/3250 RPM ± 10%	1,428/1,700 m³/hr	19.81/15.24 mmH2O	70 db(A)	50,000 hrs @ 55 °C
	ø 10" X 3-1/2"				840/1000 CFM	0.78/0.60 inchH2O		
AR280G115XBTM	280 mm X 280 mm X 89 mm	100-120 VAC 50/60 Hz	155/210 W ± 10%	2800/3200 RPM ± 10%	1,956/2,208 m³/hr	30.48/19.05 mmH2O	73 db(A)	50,000 hrs @ 55 °C
	11" X 11" X 3.5"				1,150/1,300 CFM	1.2/0.75 inchH2O		
AC Axial Fans - 230 V								
AR8038230XBT	80 mm X 80 mm X 38 mm	200-240 VAC 50/60 Hz	17/12 W ± 10%	2400/2900 RPM ± 10%	41/48 m³/hr	3.5/4.9 mmH2O	33/38 db(A)	50,000 hrs @ 25 °C
	3-5/32" X 3-5/32" X 1-1/2"				24/28.4 CFM	0.14/0.19 inchH2O		
AR8038230XBTP	80 mm X 80 mm X 38 mm	200-240 VAC 50/60 Hz	14/12 W ± 10%	2700/3250 RPM ± 10%	42/54 m³/hr	4.06/5.59 mmH2O	29 db(A)	80,000 hrs @ 45 °C
	3-5/32" X 3-5/32" X 1-1/2"				26/31 CFM	0.16/0.22 inchH2O		
AR12038230XBT	120 mm x 120 mm x 38 mm	200-240 VAC 50/60 Hz	17/15 W ± 10%	2650/3000 RPM ± 10%	143/163 m³/hr	7.5/7.8 mmH2O	43/47 db(A)	50,000 hrs @ 25 °C
	4-23/32" X 4-23/32" X 1-1/2"				84/96 CFM	0.30/0.31 inchH2O		
AR12038230XBTP	120 mm x 120 mm x 38 mm	200-240 VAC 50/60 Hz	16/14 W ± 10%	2600/3050 RPM ± 10%	180/210 m³/hr	7.62/8.13 mmH2O	45 db(A)	80,000 hrs @ 45 °C
	4-23/32" X 4-23/32" X 1-1/2"				106/125 CFM	0.30/0.32 inchH2O		
AR17251230XBT	172 mm X 150 mm X 51 mm	200-240 VAC 50/60 Hz	38/36 W ± 10%	2700/3000 RPM ± 10%	298/306 m³/hr	12/7.5 mmH2O	56/58 db(A)	50,000 hrs @ 25 °C
	6-49/64" X 5-29/32" X 2-1/64"				175/180 CFM	0.47/0.30 inchH2O		
AR17251230XBTM	172 mm X 150 mm X 51 mm	200-240 VAC 50/60 Hz	26/35 W ± 10%	2750/3150 RPM ± 10%	354/426 m³/min	13.97/14.73 mmH2O	58 db(A)	50,000 hrs @ 55 °C
	6-49/64" X 5-29/32" X 2-1/64"				210/250 CFM	0.55/0.58 inchH2O		
AR225G230XBTM	225 mm X 240 mm X 80 mm	200-240 VAC 50/60 Hz	60/80 W ± 10%	2700/3100 RPM ± 10%	918/1,056 m³/min	20.32/18.8 mmH2O	66 db(A)	45,000 hrs @ 55 °C
	8.9" X 9.5" X 3.1"				540/620 CFM	0.8/0.74 inchH2O		
AR25089C230XBTP	ø 254 X 89 mm	200-240 VAC 50/60 Hz	23/35 W ± 10%	1450/1680 RPM ± 10%	780/930 m³/hr	10.92/11.94 mmH2O	45 db(A)	80,000 hrs @ 35 °C
	ø 10" X 3-1/2"				460/550 CFM	0.43/0.47 inchH2O		
AR25089S230XBTP	ø 254 X 89 mm	200-240 VAC 50/60 Hz	60/75 W ± 10%	2600/2700 RPM ± 10%	1,392/1,464 m³/hr	19.81/18.54 mmH2O	65 db(A)	80,000 hrs @ 35 °C
	ø 10" X 3-1/2"				820/860 CFM	0.78/0.73 inchH2O		
AR25089G230XBTM	ø 254 X 89 mm	200-240 VAC 50/60 Hz	95/105 W ± 10%	2800/3250 RPM ± 10%	1,428/1,700 m³/hr	19.81/15.24 mmH2O	70 db(A)	50,000 hrs @ 55 °C
	ø 10" X 3-1/2"				840/1000 CFM	0.78/0.60 inchH2O		
AR280G230XBTM	280 mm X 280 mm X 89 mm	200-240 VAC 50/60 Hz	155/210 W ± 10%	2800/3200 RPM ± 10%	1,956/2,208 m³/hr	30.48/19.05 mmH2O	73 db(A)	50,000 hrs @ 55 °C
	11" X 11" X 3.5"				1,150/1,300 CFM	1.2/0.75 inchH2O		
AC Axial Fans - 460 V								
AR25089G440XBTM	ø 254 X 89 mm	440-480 VAC 50/60 Hz	95/105 W ± 10%	2800/3250 RPM ± 10%	1,428/1,700 m³/hr	19.81/15.24 mmH2O	70 db(A)	50,000 hrs @ 55 °C
	ø 10" X 3-1/2"				840/1000 CFM	0.78/0.60 inchH2O		
AC Axial Fans - 24 V - Metal Impeller								
AR1203824XBTM	120 mm x 120 mm x 38 mm	24-28 VAC 50/60 Hz	21/20 W	2550/3100 RPM	150/180 m³/hr	6.35/5.59 mmH2O	48 db(A)	50,000 hrs @ 55 °C
	4-23/32" X 4-23/32" X 1-1/2"				90/105 CFM	0.25/0.22 inchH2O		
AR1725124XBTM	172 mm X 150 mm X 51 mm	24-28 VAC 50/60 Hz	47/42 W	2750/3100 RPM	312/354 m³/hr	12.97/12.45 mmH2O	58 db(A)	50,000 hrs @ 55 °C
	6-49/64" X 5-29/32" X 2-1/64"				185/210 CFM	0.55/0.49 inchH2O		
AC Axial Fans - with dry contact (with output relay) - 115 V & 230 V								
AR12038115XBTP (R4)	120 mm x 120 mm x 38 mm	85-256 VAC 50/60 Hz	10/8 (6.5) W	3000 RPM	228 m³/hr	10.67 mmH2O	47 db(A)	70,000 hrs @ 40 °C
	4-23/32" X 4-23/32" X 1-1/2"				134 CFM	0.42 inchH2O		
AR12038230XBTP (R4)	120 mm x 120 mm x 38 mm	85-256 VAC 50/60 Hz	10/8 (6.5) W	3000 RPM	228 m³/hr	10.67 mmH2O	47 db(A)	70,000 hrs @ 40 °C
	4-23/32" X 4-23/32" X 1-1/2"				134 CFM	0.42 inchH2O		
AR12038115XBTP (R6)	120 mm x 120 mm x 38 mm	85-256 VAC 50/60 Hz	10/8 (6.5) W	3000 RPM	228 m³/hr	10.67 mmH2O	47 db(A)	70,000 hrs @ 40 °C
	4-23/32" X 4-23/32" X 1-1/2"				134 CFM	0.42 inchH2O		
AR12038230XBTP (R6)	120 mm x 120 mm x 38 mm	85-256 VAC 50/60 Hz	10/8 (6.5) W	3000 RPM	228 m³/hr	10.67 mmH2O	47 db(A)	70,000 hrs @ 40 °C
	4-23/32" X 4-23/32" X 1-1/2"				134 CFM	0.42 inchH2O		

Axial Fan product codes ending with P or () are for plastic impellers, product codes ending with M are for metal impellers

MECHANICAL THERMOSTATS

Normally Open & Normally Closed

TTEC

Certificates

- CSA and CSAus Listed, File Number 80012071
- UL and cUL Recognized, File Number E484831
- CE Compliant

Application

The TTEC series are thermostat controllers used to regulate the temperature inside industrial control panels or cabinets and control cabinet accessories. The TTEC series control fans, heaters, and switch loads. TTEC-100 and TTEC-200 are identical except the TTEC-100 (Red) is Normally Closed which opens at temperature rise, and turns the Heater off, the TTEC-200 (Blue) is Normally Open which closes at temperature rise, and turns the Fan/Fan Filter on.

Features

- Controls a wide range of enclosure temperatures from 14 °F to 176 °F (-10 °C to +80 °C)
- Both are available in Fahrenheit or Celsius
- Mechanical NC and NO Thermostats
- Flame retardant housing, UL 94-V0
- Mountable on three different sized DIN Rails (DIN Rail 35 mm, DIN Rail 32 mm, and DIN Rail 15 mm)

Color

- RAL 7035 - Light Gray



TECHNICAL SPECIFICATIONS

Catalog No.	TTEC -100	TTEC - 200
Function	Normally Closed	Normally Open
Terminal Operated	Between 11 & 12	Between 23 & 24
VDE Rating	250 VAC, 15 A, 50 Hz	
UL Rating	125 VAC, 15 A, 60 Hz	
Setting Temperature	-10 to +80 °C (+14 to 176 °F)	
Design and Test Standard	UL 60730-1	
	UL 60730-2-9	
	UL 60730-2-13	
	CAN/CSA-E60730 - 1:15 CAN/CSA-E60730-2-9:15	
Hi-Pot Test	1800 VAC 0.5 mA, 1 sec	
Mounting	Rail 35 mm according to EN 60715	
	Rail 32 mm according to EN 60715	
	Rail 15 mm according to EN 60715	
Weight	50 gram / 0.11 lb	
Dimensions	60 mm X 34 mm X 47 mm (2.36" X 1.34" X 1.85")	
Color	RAL 7035-Light Gray	
Electrical Connections	2-Pole for wires section of 12 AWG	
Housing Material	PA 6 UL 94-V0	
Environmental	Indoor	
Hysteresis	Approx. ± 5 °C	
Sensing Element	Bimetal	
Control Type	Operating Control, Type 1	
Rated Impulse Voltage	2500	
Operating temperature	- 20 to +80 °C / - 4 to +176 °F	
Shipping and Storage Temperature	- 40 to +80 °C / -40 to +176 °F	

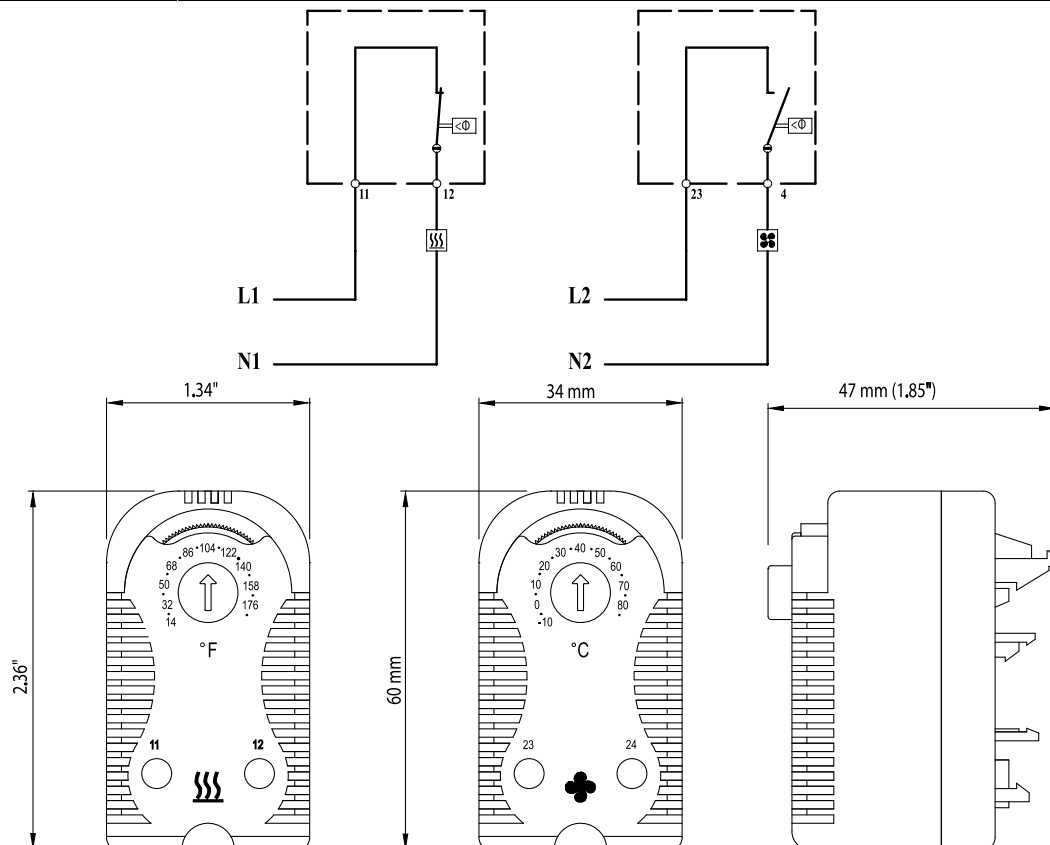

HUMIDITY CONTROL MECHANICAL HYGROSTAT

HYTEC

Certificates

- CSA and CSAus Listed, File Number 80012071
- UL and cUL Recognized, File Number E484831
- CE Compliant

Application

The HYTEC-100 is designed to control the relative humidity inside of enclosures and electrical panels. The HYTEC-100 starts the heater in order to avoid formation of condensation in enclosures. Designed to protect electronic circuits, preventing the absorption of moisture by electrical and electronic components inside of the enclosure.

Features

- Controls a wide range of enclosure relative humidity from 10% to 90%
- Operating Temperature: 0 °C to +60 °C / 32 °F to 140 °F
- Can be used for both applications; Humidifiers and Dehumidifiers
- Mechanical Hygrostat
- Mountable on 35 mm DIN Rail
- Flame retardant housing, UL 94-V0

Color

- RAL 7035 - Light Gray



TECHNICAL SPECIFICATIONS

Catalog No.	HYTEC-100			
Terminal Operated	Between 1 & 2		Between 1 & 3	
Voltage	240 VAC	120 VAC	240 VAC	120 VAC
Full Load	5 A	10 A	2.2 A	4.4 A
Locked Load	22.5 A	45 A	13.2 A	26.5 A
Resistive Load	6 A	12 A	3 A	6 A
Application	Dehumidifier		Humidifier	
	Normally Closed		Normally Open	
	Heater		Fan	
Design and Test Standard	UL 60730-1			
	UL 60730-2-9			
	UL 60730-2-13			
	CAN/CSA-E60730-1:15			
	CAN/CSA-E60730-2-9:15			
Withstanding Voltage	AC 1500 V 1 min or AC 1800 V 1 sec			
Insulation Resistance	Min 100 mΩ at DC 500 V			
Calibration Point	42% RH at room temperature 23 °C ± 2 °C / 74 °F ± 2 °F			
Mounting	Rail 35 mm according to EN 60715			
Weight	170 gram / 0.375 lb			
Dimensions	101 mm x 57 mm x 55 mm / 3.98" x 2.24" x 2.17"			
Color	RAL 7035			
Electrical Connections	3-Pole screw terminal for wires section of .75/4 mm ² - AWG 18/12			
Housing Material	PA 6 UL 94-V0			
Environmental	Indoor			
Control Type	Operating Control, Type 1			
Rated Impulse Voltage	2500			
Hysteresis	Approx. 5% RH			
Sensing Element	Synthetic Fiber			
Operating Temperature	0 °C to +60 °C / 32 °F to 140 °F			
Shipping and Storage Temperature	-40 °C to 60 °C / -40 °F to 140 °F			

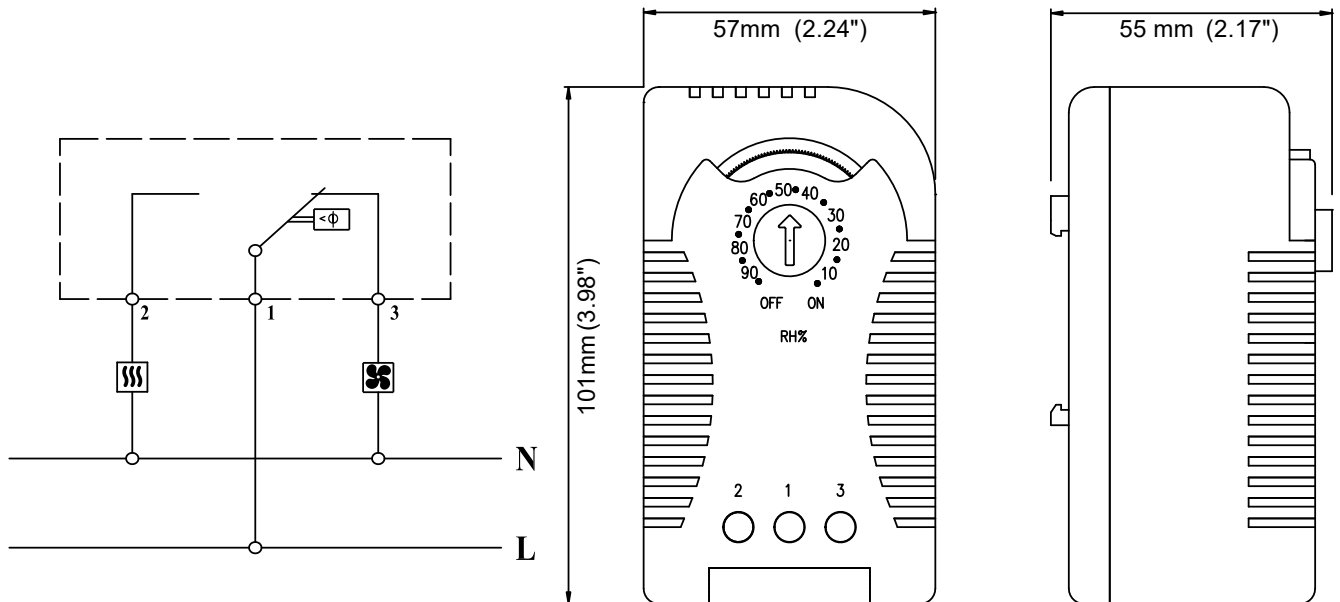

ELECTRONIC THERMOSTATS

Normally Open & Normally Closed

ETEC

Certificates

- UL and cUL Listed - File Number E484831
- CE Compliant

Application

The ETEC-400 series is an electronic thermostat controller used to regulate the temperature inside industrial control panels or cabinets and control cabinet accessories. ETEC-400 is both a Normally Open and Normally Closed thermostat to control Heaters, Fans, Fan Filters, Thermoelectric cooling Units, Air Conditioners, Heat Exchangers, Signal devices, etc.

Features

- Controls a wide range of enclosure temperatures from -40 °F to +185 °F (-40 °C to +85 °C)
- Both are available in Fahrenheit or Celsius
- NC and NO Thermostats
- Flame retardant housing, UL 94-V0
- Mountable on 35 mm Din Rail EN 60715

Color

- RAL 7035 - Light Gray



TECHNICAL SPECIFICATIONS

Part No.	ETEC-400
Contact type	Normally Open and Normally Closed- Power Relay
Switch Difference	3 K (± 1 K) at +25 °C (+77 °F)
Operating and Storage Temperature	-40 °F to +185 °F (-40 °C to +85 °C)
Contact Rating	120/240 VAC - 20 A (NO) / 20 A (NC) 24 VDC - 20A (NO) / 20 A (NC)
Mounting	DIN Rail 35 mm - EN 60715
Electrical Connection	7-Pole screw terminal for wire section 2.5 mm ² - 26 ~ 12 AWG - 0.5 N.m Screw Torque
Housing	PA 6 UL 94-V0 Flame Retardant
Dimensions	70 mm x 56 mm x 50 mm (2.76" x 2.20" x 1.97")
Weight	108 gram / 0.24 lb
Color	RAL 7035 - Light Grey

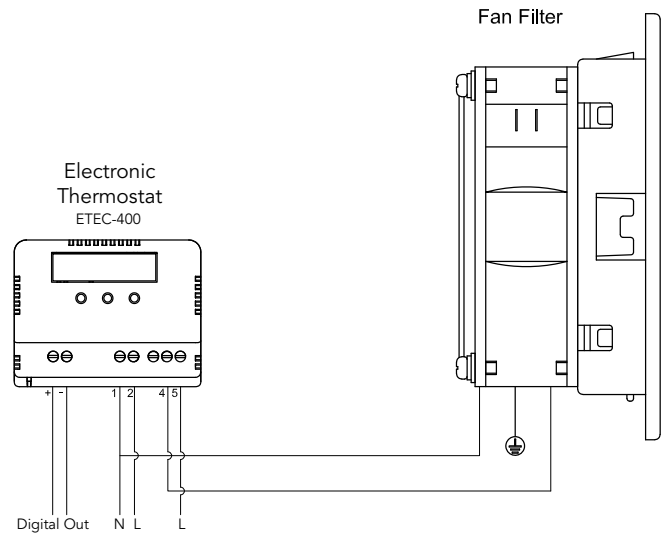
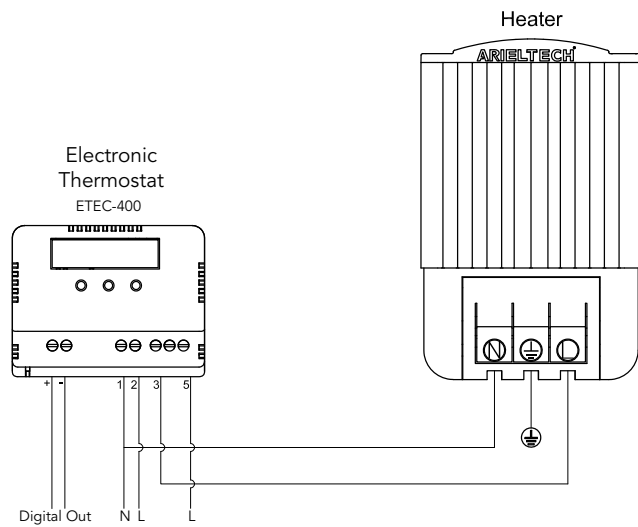
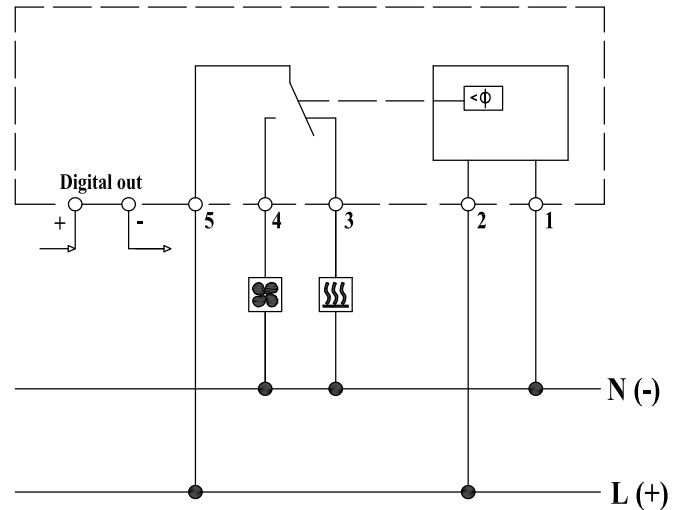
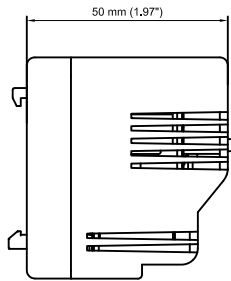
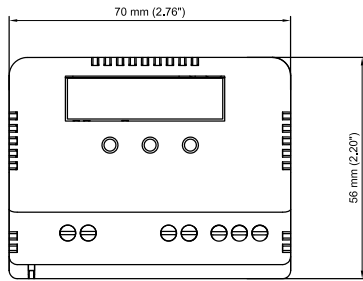

ELECTRONIC HYGROSTAT HUMIDISTAT CONTROLLER

ETEC

Certificates

- UL and cUL Listed - File Number E484831
- CE compliant

Application

The ETEC-600 series is an electronic hygrostat controller used to regulate the humidity levels inside industrial control panels or cabinets and control cabinet accessories. ETEC-600 Designed to protect electronic circuits, preventing the absorption of moisture by electrical and electronic components inside of the enclosure.

Features

- Controls a wide range of enclosure relative humidity up to 90%
- Electronic Humidistat
- Flame retardant housing, UL 94-V0
- Mountable on DIN Rail 35 mm - EN 60715

Color

- RAL 7035 - Light Gray



TECHNICAL SPECIFICATIONS

Part No.	ETEC-600
Contact type	Normally Open and Normally Closed- Power Relay
Switch Difference	5 % RH (± 3 % RH) at +25 °C (+77 °F)
Operating and Storage Temperature	-40 °F to +185 °F (-40 °C to +85 °C)
Contact Rating	120/240 VAC - 20 A (NO) / 20 A (NC) 24 VDC - 20A (NO) / 20 A (NC)
Mounting	DIN Rail 35 mm - EN 60715
Electrical Connection	7-Pole screw terminal for wire section 2.5 mm ² - 26 ~ 12 AWG - 0.5 N.m Screw Torque
Housing	PA 6 UL 94-V0 Flame Retardant
Dimensions	70 mm x 56 mm x 50 mm (2.76"x2.20"x1.97")
Weight	108 gram / 0.24 lb
Color	RAL 7035 - Light Grey

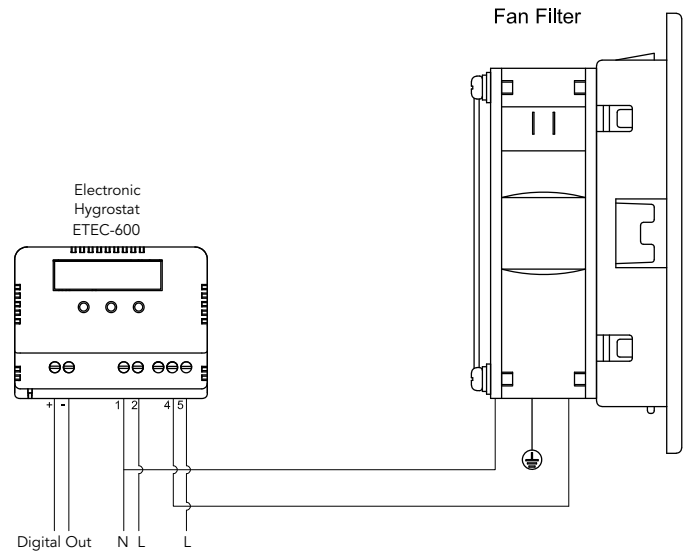
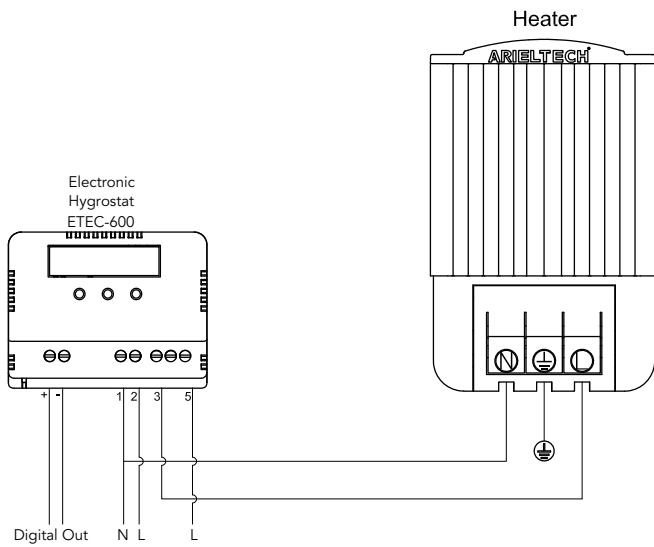
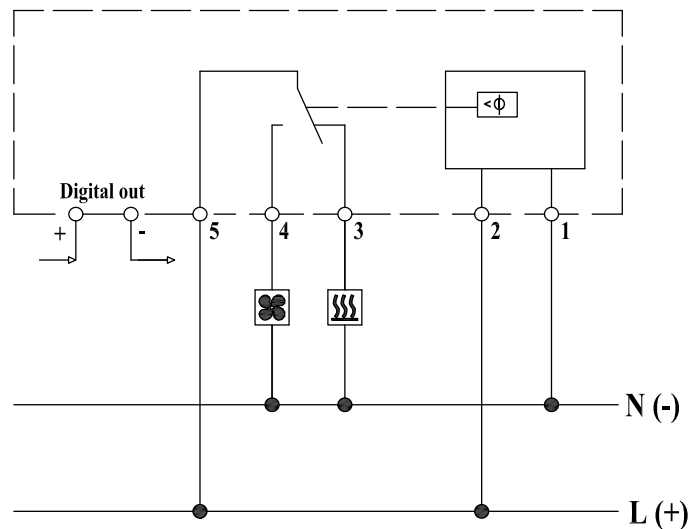
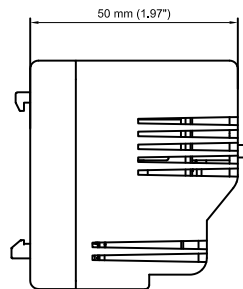
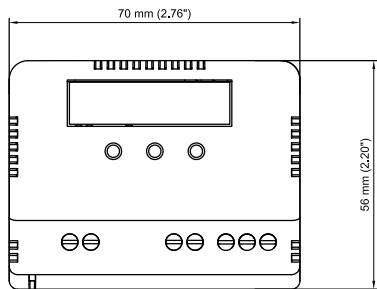

HEATER

HEATEC Series

HEATEC

Certificates

- UL and cUL Recognized, File Number E515368
- CSA and CSAus Listed
- CE Compliant

Application

Provides protection from condensation and low temperatures in Control Panels, Electronic Enclosures, Hydraulic and Pneumatic machinery

Features

- Safe, Reliable and consistent heat for long periods by means of PTC (Positive Temperature Coefficient) heater
- Highly efficient and low profile
- Connects easily with push connectors for 3 wires. From AWG 20 to AWG 16 (0.5 - 2.5 mm²).
- Built in safety feature prevents overheating
- Used with Normally Closed Thermostat and Hygrostat
- Black anodized aluminum housing
- Mounts easily on 35 mm DIN Rail EN 60715
- Available in 35 Watt to 150 Watt
- Operating/storage temperature is -45 to + 70 °C (-49 to +158 °F)

Color

- Black



TECHNICAL SPECIFICATIONS

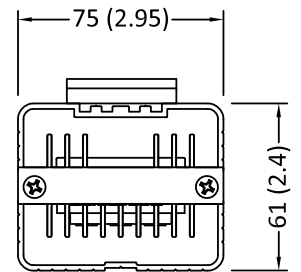
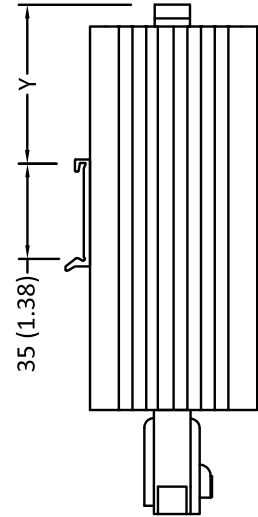
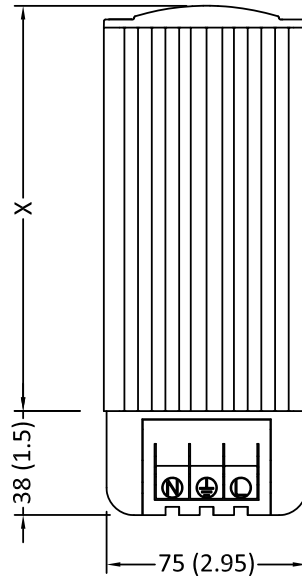
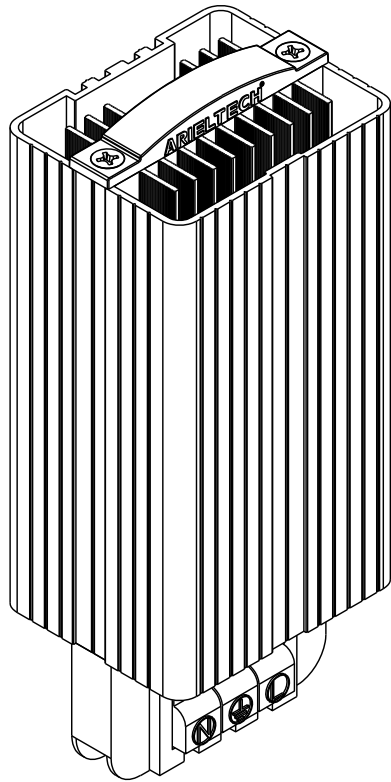

● All Dimensions : mm (Inch)

Model No.	X	Y
HEATEC-35	78±0.5 mm (3 1/16"±3 15/16")	20±1 mm (13/16"±1/16")
HEATEC-45		
HEATEC-60	148±0.5mm (5 13/16"±3 15/16")	55±1 mm (2 3/16"±1/16")
HEATEC-80		
HEATEC-100		
HEATEC-130	198±0.5mm (7 13/16"±3 15/16")	55±1 mm (2 3/16"±1/16")
HEATEC-150		

Technical Data

Heater Model No.	Power* (WATT)	Voltage (VAC/VDC)	Inrush Current 110/240 VAC	Dimensions mm (Inch)	Weight KG(lb)	Max surface temp °C (°F)
HEATEC-035	35	110-240	1.2 A/2.5 A	116x75x61 (4.57x2.95x2.4)	0.5 (1.1)	90 (194)
HEATEC-045	45	110-240	1.8 A/3.5 A	116x75x61 (4.57x2.95x2.4)	0.5 (1.1)	95 (203)
HEATEC-060	60	110-240	2.0 A/3.8 A	186x75x61 (7.32x2.95x2.4)	0.7 (1.55)	95 (203)
HEATEC-080	80	110-240	2.2 A/4.2 A	186x75x61 (7.32x2.95x2.4)	0.7 (1.55)	105 (221)
HEATEC-100	100	110-240	3.5 A/6.5 A	186x75x61 (7.32x2.95x2.4)	0.7 (1.55)	110 (230)
HEATEC-130	130	110-240	4.0 A/ 7.0 A	236x75x61 (9.29x2.95x2.4)	0.9 (2)	110 (230)
HEATEC-150	150	110-240	4.8 A/8.8 A	236x75x61 (9.29x2.95x2.4)	0.9 (2)	115 (239)

* Attained values at 20°C (68 °F) ambient temperature and 240 VAC.



THERMOELECTRIC COOLING UNIT

COLTEC

Certificates

- CE Compliant

Application

- Air to Air Thermoelectric Cooling unit (COLTECN series) Telecommunication Battery Temperature Control, Industry Equipment Power Cabinet Cooling, etc.
- Air to Plate Thermoelectric Cooling unit (COLTECAP series) Medical Devices, Instrument and Laboratory Test Equipment, Direct Contact Cooling Design, etc.
- Air to Liquid Thermoelectric Cooling unit (COLTECAL series) Medical Hairdressing Devices, Laser Equipment, or other needed cooling device applications.
- Liquid to Liquid Thermoelectric Cooling unit (COLTECLL series) LED Manufacturing Evaporating Systems, Analytic Instruments, etc.

Features

- Zero maintenance, no filters, compressors, or refrigerant required
- Safe for the environment
- No air exchange between ambient and cabinet air
- Continuous worry-free operation
- Installs vertically or horizontally. Can be installed on any plate thickness by means of screws
- Uses quality ball bearing fans
- Standard direction airflow
- Ingress Protection is NEMA 12/ IP 55

Color

- RAL 9003 – White

Advantages

Thermoelectric Cooling Units have no moving parts and do not require the use of chlorofluorocarbons. Therefore, they are safe for the environment, reliable, and virtually maintenance-free. They can be operated in any orientation and are ideal for cooling devices that might be sensitive to mechanical vibration. Their compact size also makes them ideal for applications that are size or weight limited, and where even the smallest compressor would have excess capacity.



CE

Air to Air Thermoelectric Cooling Unit (COLTECN series)

Model	Cooling Capacity	Voltage	Stable Current	Dimensions		Weight		Ambient Temp. Range	
	(W-BTU/hr)			(Vdc)	(A)	(mm)	(Inch)	(Kg)	(lb)
COLTECN01512-55	19-65	12	2.2 ±10%	121x100x80	4.76x3.94x3.15	0.6	1.32	-10 TO +60	14 TO +140
COLTECN02512-55	25-85	12	2.5 ±10%	108X100X80	4.25X3.94X3.15	0.6	1.32	-10 TO +60	14 TO +140
COLTECN03512-55	35-120	12	3.9 ±10%	144X120X103	5.67X4.73X4.05	1.1	2.43	-10 TO +60	14 TO +140
COLTECN05012-55	50-170	12	8.2 ±10%	148X160X123	5.83X6.30X4.84	1.8	3.97	-10 TO +60	14 TO +140
COLTECN05024-55	50-170	24	4.0 ±10%	160X122X147	6.30X4.80X5.79	1.8	3.97	-10 TO +60	14 TO +140
COLTECN-08024-55	80-270	24	5.0 ±10%	241X156X210	9.49X6.14X8.27	2.8	6.17	-10 TO +60	14 TO +140
COLTECN10012-55	100-340	12	12.6 ±10%	241X156X210	9.49X6.14X8.27	2.8	6.17	-10 TO +60	14 TO +140
COLTECN10024-55	100-340	24	8.2 ±10%	200X180X180	7.87x7.09x7.09	3.0	6.61	-10 TO +60	14 TO +140
COLTECN10048-55	100-340	48	2.5 ±10%	200x180x180	7.87x7.09x7.09	3.0	6.61	-10 TO +60	14 TO +140
COLTECN20048-55	200-680±10%	48	7.5 ±10%	400X200X180	15.75X7.87X7.09	7.5	16.53	-10 TO +60	14 TO +140

Air to Plate Thermoelectric Cooling Unit (COLTECAP series)

Model	Cooling Capacity	Voltage	Stable Current	Dimensions		Weight		Ambient Temp. Range	
	(W-BTU/hr)			(Vdc)	(A)	(mm)	(Inch)	(Kg)	(lb)
COLTECAP04012	42-145	12	4.1 ±10%	122X100X82	4.80X3.94X3.23	0.8	1.76	0 TO +60	32 to +140
COLTECAP05012	50-170	12	8.5 ±10%	160x122x82	6.30x4.80x3.23	1.1	2.43	0 TO +60	32 to +140
COLTECAP05024	50-170	24	4.3 ±10%	160x122x82	6.30x4.80x3.23	1.1	2.43	0 TO +60	32 to +140
COLTECAP08024	80-270	24	4.3 ±10%	203x155x152	7.99x6.10x4.98	3.6	7.94	0 TO +60	32 to +140

Air to Liquid Thermoelectric Unit (COLTECAL series)

Model	Cooling Capacity	Voltage	Stable Current	Dimensions		Weight		Ambient Temp. Range	
	(W-BTU/hr)			(Vdc)	(A)	(mm)	(Inch)	(Kg)	(lb)
COLTECAL05012	50-170	12	8.0 ±10%	160X120X84	6.30X4.7X3.3	1.5	3.30	-10 TO +55	14 to +131
COLTECAL05024	50-170	24	4.0 ±10%	160X120X84	6.30X4.7X3.3	1.5	3.30	-10 TO +55	14 to +131
COLTECAL08024	80-270	24	5.1 ±10%	203x155x147	7.99x6.10x5.8	3.1	6.83	-10 TO +55	14 to +131
COLTECAL10012	100-340	12	14.3 ±10%	203x155x147	7.99x6.10x5.8	3.1	6.83	-10 TO +55	14 to +131
COLTECAL10024	100-340	24	5.7 ±10%	124X122X97	8.66X6.10X3.8	1.8	3.96	-10 TO +55	14 to +131
COLTECAL15024	150-510	24	8.2 ±10%	160X155X150	6.3X6.1X5.9	3.1	6.83	-10 TO +55	14 to +131
COLTECAL30024	300-1025	24	14 ±10%	275X161X161	10.83X6.34X6.34	5.0	10.91	-10 TO +55	14 to +131

Liquid to Liquid Thermoelectric Cooling Unit (COLTECLL series)

Model	Cooling Capacity	Voltage	Stable Current	Dimensions		Weight		Ambient Temp. Range	
	(W-BTU/hr)			(Vdc)	(A)	(mm)	(Inch)	(Kg)	(lb)
COLTECLL08024	80-270	24	4.2	200x36x60	7.87x1.42x2.36	1.2	2.65	0 TO +60	32 to +140
COLTECLL32024	320-1090	24	13.3	240x102x60	9.45x4.00x2.36	3.7	8.16	0 TO +60	32 to +140

Accessories Filter Mat

FM-4 series filter mats are standard series which guarantees IP54-NEMA 12 Ingress Protection. To maintain a high performance of the FM-4 series, periodically check filter mats. FM-4 series are fully washable.

Model	Description	Quantity Per Pack
FTEC10-FM-4	Filter Mat IP54-NEMA 12 (4" Filter 116X116)	5
FTEC16-FM-4	Filter Mat IP54-NEMA 12 (6" Filter 160X160)	5
FTEC20-FM-4	Filter Mat IP54-NEMA 12 (8" Filter 206X206)	5
FTEC26-FM-4	Filter Mat IP54-NEMA 12 (10" Filter 260X260)	5
FTEC32-FM-4	Filter Mat IP54-NEMA 12 (12" Filter 326X326)	5

FM-5 series filter mats are the super series which guarantees IP55-NEMA 12 & 3R Ingress Protection. To maintain a high performance of FM-5 series, periodically check filter mats. FM-5 series are fully washable.

Model	Description	Quantity Per Pack
FTEC10-FM-5	Filter Mat IP55-NEMA 12 & 3R (4" Filter 116X116)	5
FTEC16-FM-5	Filter Mat IP55-NEMA 12 & 3R (6" Filter 160X160)	5
FTEC20-FM-5	Filter Mat IP55-NEMA 12 & 3R (8" Filter 206X206)	5
FTEC26-FM-5	Filter Mat IP55-NEMA 12 & 3R (10" Filter 260X260)	5
FTEC32-FM-5	Filter Mat IP55-NEMA 12 & 3R (12" Filter 326X326)	5

The filter mats are made of high-performance nonwovens produced in-house from elastic, break-resistant polyolefin fibers with thermal bonding.

The filter mats can be easily cleaned by washing, beating or spraying, and can then be re-used. Even after washing, the filter mats remain dimensionally stable, thus retaining their technical filtering properties.

The fire class remains unaltered.

Filter mats satisfy the stringent requirements of Fire Class F1 according to DIN 53 438 and are thus self-extinguishing.

Fan Power Cord

Model No. Information:

- AR45-05-XX (XX=cord length, Meter or Feet)
- Fit tib size: 1W. X Thk.0.5mm for AR45-05
- Material: PVC compound UL94V-0

Plug:

Contact:

- brass for AR45-05
- Fit tib size: 3.1W. X Thk.0.5mm for AR45-05
- Material: PVC compound UL94V-0

Cord:

- UL/CSA listed spt-1 18awg x 2c 105° black
- Ending: cut off or stripped / tinned are optional

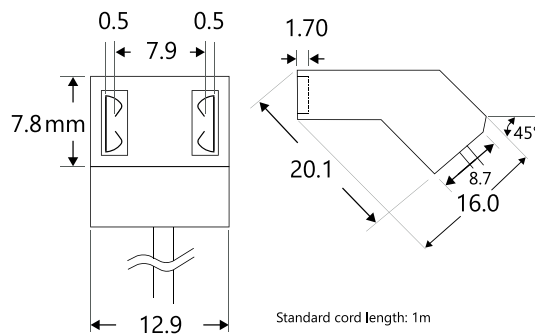

Metal Fan Guard

FG series

Model	Description	Quantity Per Pack
FTEC10-FG	Metal Fan Guard For 3" – 80 mm x 80 mm Fan	50
FTEC16-FG	Metal Fan Guard For 4" – 120 mm x 120 mm Fan	50
FTEC26-FG	Metal Fan Guard For 6" – 172 mm x 150 mm Fan	50
FTEC32-FG	Metal Fan Guard For 10" – ø 254 mm Fan	50

Standard Warranty for All Products

Ariel Technology, Inc. ("Manufacturer")

Ariel Technology Inc. is the manufacturer (the "Manufacturer") of the products (the "Products") contained within the Products Instruction Manual and Product Catalogues. This warranty solely applies to the Products manufactured by the Manufacturer.

Warranty Terms and Conditions ("Warranty Terms"):

1. The Manufacturer warrants that on the date of shipment the Products are of the kind and quality described herein and are free of non-conformities in workmanship and material.

Buyer's exclusive remedy for a nonconformity in any item of the Products shall be the replacement (at the Manufacturer's option) of the item and any affected part of the Products, provided: (a) the non conforming product failed during normal, intended and proper use as per the Product's Instruction Manual and Product Catalogue of such product; (b) the failure is not attributable to improper or unauthorized application, storage, handling, modification, installation or use; and (c) the Manufacturer is given the reasonable opportunity to inspect the non-conforming product.

2. The Manufacturer's obligation to repair or replace shall be in effect for a period of one (1) year from initial use of the Products but not more than eighteen (18) months from the Manufacturer's shipment of the Products, provided the Buyer has sent a written notice within that period of time to the Manufacturer that the Products do not conform to the above warranty. Any replaced Product shall be warranted for the remainder of the original period of notification set forth above, but in no event less than 12 months from repair or replacement. At its expense, the Buyer shall remove and ship to the Manufacturer any such nonconforming items and shall reinstall the replaced Product. The shipment address for the Manufacturer is: Unit 9- 1111 Gorham Street, Newmarket, ON L3Y 8X8. The Buyer shall grant the Manufacturer access to the Product (intended to be replaced) at all reasonable times in order for the Manufacturer to determine any nonconformity in the Product. The Manufacturer shall have the right of disposal of the Product replaced by it. If the Manufacturer is unable or unwilling to replace, or if replacement Product does not remedy the nonconformity, the Manufacturer and the Buyer shall negotiate an equitable adjustment in the purchase price, which may or may not include a full refund of the price of such nonconforming Product.

3. Except for as provided in the Products Instructions Manual, the Manufacturer does not warrant and is not responsible for:

(i) Failures, defects or limitations in performance caused by or due to, in whole or in part: a) power outages/failures or power surges, water or floods, snow, ice, weather conditions, such as excessive cold or hot temperatures, excessive humidity levels, accidents, use of Products in corrosive environments, failure caused by third parties actions, acts of God, or other such events outside the Manufacturer's control; b) customer's non-compliance with the Manufacturer's Products Instruction Manual and Product Catalogues, negligence, mishandling, improper use or storage, attempts to repair or alter the Products in any way with consulting the Manufacturer, and servicing of the Products; and c) use of Products in combination with other equipment or products which lack a qualified agency's approval for quality. Any alternations or modifications to the whole or a part of the Product without the Manufacturer's prior written authorization, voids this Warranty.

4. THE MANUFACTURER HEREBY DISCLAIMS ALL OTHER REPRESENTATIONS, CONDITIONS AND WARRANTIES, EXPRESS OR IMPLIED, INCLUDING THOSE CONTAINED IN THE SALES OF GOODS ACT, ONTARIO, R.S.O. 1990, c. S.1. AND THE CIVIL CODE OF QUEBEC, CQLR CCQ-1991. THE MANUFACTURER SPECIFICALLY DISCLAIMS, INCLUDING BY WAY OF EXAMPLE AND NOT LIMITATION, THE IMPLIED WARRANTIES OF TITLE, MERCHANTABILITY, NON-INFRINGEMENT AND FITNESS FOR A PARTICULAR PURPOSE. IN NO EVENT SHALL THE MANUFACTURER BE LIABLE FOR ANY INCIDENTAL, SPECIAL, CONSEQUENTIAL OR PUNITIVE DAMAGES, WHETHER ARISING IN CONTRACT, TORT OR OTHERWISE UNDER ANY LEGAL PRINCIPLE, THEORY OR LAWS, EVEN IF IT HAS BEEN ADVISED OF THE POSSIBILITY OF SUCH DAMAGES. THE LIMITATIONS SET FORTH HERE WILL APPLY EVEN IF THE REMEDIES OF ERROR CORRECTION, REPAIR OR REPLACEMENT, REPERFORMANCE OF SERVICES AND REFUND OF PAYMENTS COMPLETELY FAIL OF THEIR ESSENTIAL PURPOSE. NOTWITHSTANDING ANYTHING HEREIN TO THE CONTRARY, THE LIMIT OF MANUFACTURER'S LIABILITY (WHETHER IN CONTRACT, TORT, NEGLIGENCE, STRICT LIABILITY, BY STATUTE OR OTHERWISE) TO CUSTOMER OR TO ANY THIRD PARTY CONCERNING THE MANUFACTURER'S PRODUCTS SOLD TO CUSTOMER AND WARRANTED HEREUNDER, THE MANUFACTURER'S PERFORMANCE OR NONPERFORMANCE, OR IN ANY MANNER RELATED TO THIS STANDARD WARRANTY TERMS, FOR ANY AND ALL CLAIMS WILL NOT IN THE AGGREGATE EXCEED THE ACTUAL AMOUNTS RECEIVED BY MANUFACTURER FOR THE SPECIFIC PRODUCT WITH RESPECT TO WHICH SUCH CLAIM IS MADE.

5. Buyer and successors of Buyer are limited to the remedies specified in this warranty and shall have no others for a nonconformity in the Products. Buyer agrees that these remedies provide Buyer and its successors with a minimum adequate remedy and are their exclusive remedies, whether Buyer's or its successors' remedies are based on contract, warranty, tort (including negligence), strict liability, indemnity, or any other legal theory, and whether arising out of warranties, representations, instructions, installations, or non-conformities from any cause.

6. The Warranty Terms are governed by and shall be construed under the laws of Ontario, Canada. In case of any dispute that may arise between the customer and the Manufacturer, the Courts of Ontario shall have the sole jurisdiction to resolve such disputes. The Manufacturer and customer explicitly agree that the terms of Sales of Goods Act, Ontario, R.S.O. 1990, c.S.1, and the United Nations Convention on Contracts for the International the Sale of Goods does not apply to the parties or any transaction between the Manufacturer and the customer.

Ariel Technology Inc. Customer Support Number: 905-895-5900



ARIELTECH[®]

9-1111 Gorham St, Newmarket
Ontario, Canada L3Y 8X8
(USA/Canada) Toll Free: 1-855-895-5900
Tel: 905-895-5900 | Fax: 905-895-5960
info@arieltech.ca | www.arieltech.ca